

---

# Classification of Forest Stands as Fuels According to the Canadian Forest Fire Behavior Prediction (FBP) System

Third ten-year Quebec forest survey program

---

Georges Pelletier, F. Eng.\*  
Jacques St-Onge, F. Tech.\*  
Pierre Bordeleau, F. Tech.\*  
Pierre De Rainville, F. Tech.\*\*  
Francine Bart, F. Tech.\*\*  
Émile Aubin, Sp. F. Tech.\*\*  
Jean-François Roy, Sp. F. Tech.\*\*  
Gaston Therriault, Sp. F. Tech.\*\*

**\*Société de protection des forêts contre le feu**

**\*\*Ministère des Ressources naturelles et de la Faune**  
Direction de l'environnement et de la protection des forêts

Quebec, October 2009

---

## Contributors

### **Société de protection des forêts contre le feu**

François Lefebvre, Philippe Dion and Gaétan Lemaire

### **Ministère des Ressources naturelles et de la Faune**

Julie Fortin, Nathalie Lavoie, Michel Huot, Louis Deschamps, Yves Dumont, Sylvie Delisle, Justine Gilbert and Sylvie Jean

## Photo credits

Stéphane Chalifour and Jacques St-Onge

## English Translation

Valerie Leger, C.Tr.

## For further information

### **Ministère des Ressources naturelles et de la Faune**

Direction des communications

5700, 4<sup>e</sup> Avenue Ouest, bureau C 409

Québec (Québec) G1H 6R1

Telephone: 418 627-8600 or 1 866 248-6936

Fax: 418 643-0720

E-mail: [services.clientele@mrnf.gouv.qc.ca](mailto:services.clientele@mrnf.gouv.qc.ca)

Website: [www.mrnf.gouv.qc.ca](http://www.mrnf.gouv.qc.ca)

Publication number: DEPF-0319

### **Société de protection des forêts contre le feu (SOPFEU)**

Jean Lesage International Airport

715, 7<sup>e</sup> rue de l'Aéroport

Québec (Québec) G2G 2S7

Telephone: 418 871-3341

Website: [www.sopfeu.qc.ca](http://www.sopfeu.qc.ca)

This publication, designed to be printed on both sides, is available at the following website address (*in French*): [www.mrnf.gouv.qc.ca/forets/fimaq/information/fimaq-information-resultats-combustible.jsp](http://www.mrnf.gouv.qc.ca/forets/fimaq/information/fimaq-information-resultats-combustible.jsp).

### **Reference (French):**

Pelletier, G., et al (2009). *Classification des peuplements forestiers en tant que combustibles selon la méthode canadienne de prévision du comportement des incendies de forêt – Troisième programme décennal d'inventaire forestier du Québec*, Québec, Société de protection des forêts contre le feu et ministère des Ressources naturelles et de la Faune, Direction de l'environnement et de la protection des forêts, 56 p.

**Keywords:** *classification, comportement, feu, forêt, incendie, méthode, protection, prévision, Québec,*  
**(French)** *type de combustible.*

### **Reference (English):**

Pelletier, G., et al (2009). *Classification of Forest Stands as Fuels According to the Canadian Forest Fire Behavior Prediction (FBP) System – Third Ten-Year Quebec Forest Survey Program*, Québec, Société de protection des forêts contre le feu et ministère des Ressources naturelles et de la Faune, Direction de l'environnement et de la protection des forêts, 51 p.

**Keywords:** *classification, fire, forest, fuel type, method, prediction, protection, Quebec.*  
**(English)**

© Government of Québec

Ministère des Ressources naturelles et de la Faune, 2009

Legal deposit – Bibliothèque et Archives nationales du Québec, 2009

ISBN: 978-2-550-58300-4

## Foreword

Data from Quebec's third ten-year forest survey program became available in December 2001. The forest fuels working group was then able to start establishing links between forest stands surveyed and types of forest fuels defined in the Canadian Forest Fire Behavior Prediction (FBP) System. The same type of work had already been done with data from the second ten-year forest survey program (1994-2001). Based on this work and the analysis of available data, it was possible to establish a new preliminary classification table of forest stands. This table was validated and corrected. Then, in the fall of 2007, we finished revising the classification rules (guidelines). The entire project was seven years in the making.

The forest fuels working group was made up of representatives from the Société de protection des forêts contre le feu (SOPFEU) and the environmental and forest protection branch of the Ministère des Ressources naturelles et de la Faune (MRNF). They brought valuable and much appreciated experience and expertise to the project. Since 2001, some of the members of the working group have left the MRNF for a well-deserved retirement. Their major contribution to this classification has been acknowledged by naming them as co-authors of this document. We would like to express our sincere gratitude for their involvement and professionalism.

The classification method described in this document was developed after flying over forest land many times, analyzing all data gathered and holding several discussions with working group members. In addition, several site visits were done. The contribution of all members of the working group was required to ensure that results met expectations. Since these persons experienced the project first hand, they may not need this document as a reminder of their work. However, to help the new generation of workers, leave an account of the work accomplished, explain the approach taken and facilitate the next fuel classification, this document is essential.

## Table of Contents

Introduction .....	1
1. Territory Surveyed .....	2
2. Fuel Classification .....	3
3. Available Forest Data .....	3
4. Classification Process .....	3
5. Classification Rules .....	6
5.1 Validation results .....	6
5.1.1 Mixedwood species groups .....	6
5.1.2 Plantations .....	11
5.1.3 Forest stands affected by mortality .....	12
5.1.4 Forest stands with lichen .....	16
5.1.5 Non-regenerated burned areas .....	16
5.1.6 Cutting with protection of regeneration and soils .....	16
5.1.7 Species groups dominated by 10-year-old jack pine regenerating and burned area under 20 years old regenerated with jack pine .....	17
5.1.8 Cedar and larch stands .....	17
5.1.9 Forest stands equivalent to C-3 .....	17
5.1.10 Type C-2 <i>true</i> and drainage class .....	17
5.1.11 Regenerated or non-regenerated wildlands .....	18
5.1.12 Young softwood plantations with undetermined species .....	18
6. Forest Fuel Classification Table (2009) .....	19
7. Comparison of 2001 and 2009 Classification Results .....	31
Conclusion .....	34
Appendix A Classification of forest stands as fuels - Second ten-year forest survey program .....	35
Appendix B Classification of forest stands as fuels - First ten-year forest survey program .....	43
Bibliography .....	50

## List of Tables and Figures

Table 1	Reconnaissance flight results for mixedwood species groups .....	8
Table 2	Reconnaissance flight results for softwood plantations.....	11
Table 3	Percentages of areas affected by a moderate or severe defoliation by ecological sub-region from 1967 to 2003 .....	13
Table 4	Reference mortality year by ecological sub-region .....	15
Table 5	Fuel classification table - Third ten-year forest survey program (2009) .....	19
Table 6	Area occupied by fuels in intensive protection zone in 2001 and 2009.....	31
Table 7	Explanations for variations in results for 2001 and 2009.....	32
Table 8	Fuel classification table - Second ten-year forest survey program (February 2006) .....	36
Table 9	Fuel classification table - First ten-year forest survey program (July 2002) .....	44
Figure 1	Reconnaissance flight zones and areas surveyed .....	2
Figure 2	Fuel classification process .....	5
Figure 3	Distribution of forest fuels in Québec in 2009.....	33



## Introduction

Since 1995, the forest fuel working group has shared the results of its work to classify forest stands as fuels (Pelletier et al, 1995, 1999 and 2001). In 2001, the group published a classification method developed using data from the second ten-year Quebec forest survey program. The classification method presented in this document describes the one developed following the completion of the third ten-year forest survey program.

After the second ten-year forest survey program, several changes in the forest situation forced us to add new rules to the classification method. Indeed, the MRNF completely reviewed its way of naming mixedwood stands and plantations. Furthermore, during the 1980s, reforestation efforts were stepped up with the objective of planting some 300 million seedlings per year, which led to the creation of 259 new forest species groups. The ecological characteristics of forest stands (e.g. deposit, drainage and presence of lichen) were also added to the database. Because of all these changes, we no longer had a base on which to classify stands resulting from the third survey. We often had to go back to square one to develop new rules.

In this document, you will find the results of our forest stand analysis along with the new classification table which serves to determine fuel types prior to a fire. The data used come from the raster-based forest information system, known as SIFORT.<sup>1</sup> To validate the classification of forest stands, the forest fuels working group carried out six forest reconnaissance flight programs. Many site visits were also made. The results of these activities enabled us to prepare a map of forest fuels for Quebec. The new classification of forest stands as fuels is based on all this work and work done in the past. It is the logical next step.

Although it is referred to in this document, the Canadian Forest Fire Behavior Prediction System (FBP) and the forest fuel types it uses are not described. Further information on this system can be found on the Canadian Forest Service (Natural Resources Canada, 2009) website.

To document previous classification work, Appendix A contains the table built using data from the second ten-year forest survey program. This table includes the changes made since its publication in September 2001. Appendix B contains the classification table built using data from the first ten-year forest survey program. However, this table has never been published. To the best of our knowledge, it was developed in 2001 to meet a request to classify all available forest data.

---

1. This system was developed by SOPFEU, the MRNF and the Société de protection des forêts contre les insectes et les maladies (SOPFIM).

## 1. Territory Surveyed

Only forest land under timber supply and forest management agreements were surveyed for the third ten-year forest survey program (from 1990 to 2001). This territory corresponds to the intensive forest fire protection zone (Figure 1). The limited protection zone was not surveyed during this survey program. However, a certain portion was surveyed during the second program. Data from the second survey program continue to be valid and are still used in the new forest stand classification method.

To validate the classification of these stands, six reconnaissance flight programs were carried out between 2001 to 2007. The four zones (West, Centre, East, Lower St. Lawrence-Gaspé Peninsula) covered by these reconnaissance flights are shown on the map below in Figure 1.

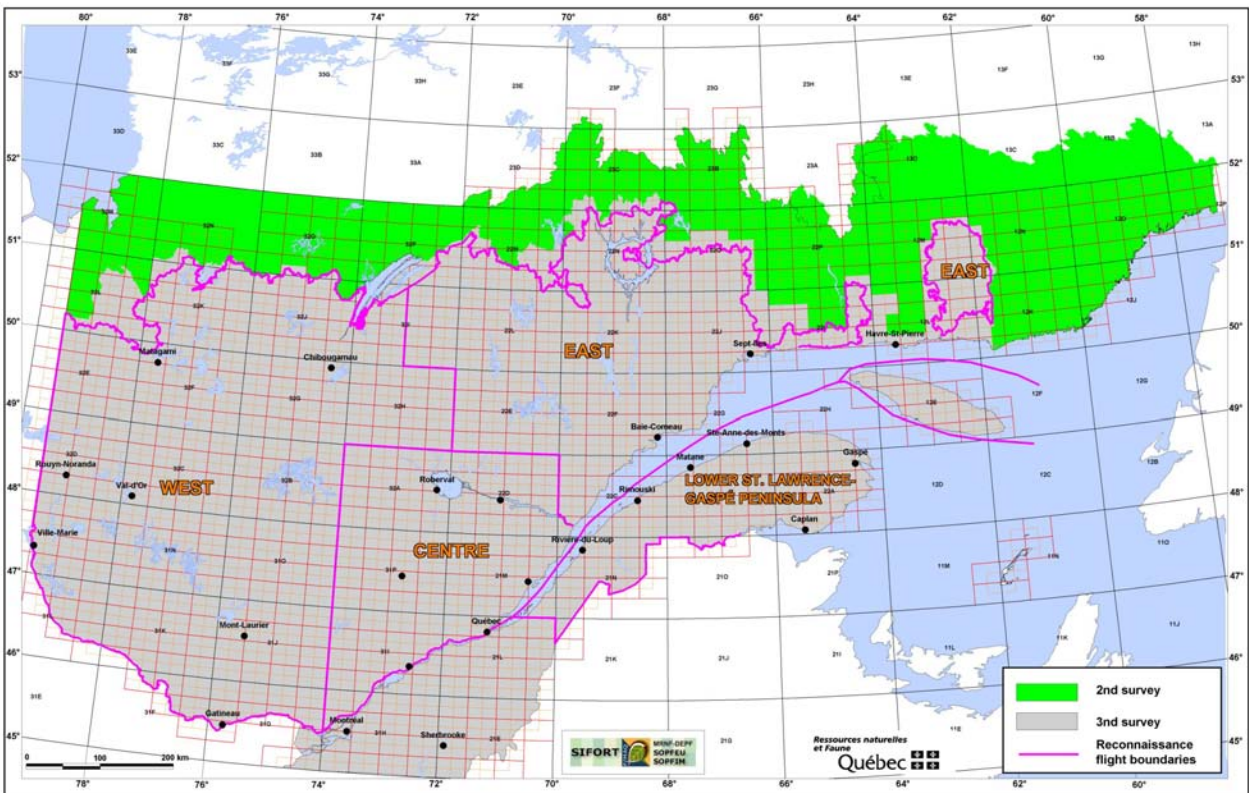


Figure 1 - Reconnaissance flight zones and territory surveyed

## 2. Fuel Classification

In 2001, three classes were established combining several fuel types of fuel. These classes are still valid and used in the new classification.

- **Fuels defined** in the Canadian FBP method: class with types C-1, C-2,<sup>1</sup> C-3, C-4, C-5, C-6, C-7, D-1, M-1, M-2, M-3, M-4, S-1, S-2, O-1a and O-1b.
- **Fuels not defined** in the Canadian FBP method: class with, among others, burned areas (BR), dry bare areas (DS) and cedar stands.
- **Non-fuels**: class with several elements such as water (EA), wet bare areas (DH) and farmland (AU).

## 3. Available Forest Data

In 2001, to classify the province's forest stands, data from the SIFORT<sup>2</sup> system (Ministère des Ressources naturelles et de la Faune, 2009) were used. For this new classification, we not only used data from the third ten-year forest survey program, which were also stored in SIFORT, but also some data from the second survey program. This information gave us the type of forest cover, stand density and the species groups present before certain initial disturbances.

The territory surveyed is classified considering not only productive and unproductive forest land, but also non-forest land.

The description and content of all data used in the forest stand classification table are found in the SIFORT users' guide (Pelletier, Dumont and Bédard, 2007). (*In French*)

## 4. Classification Process

There are four steps in the forest stand classification process (Figure 2). The first step is the **acquisition** of original or updated forest data (from SIFORT) and historical data on forest fires. The second step is the **classification** of data according to preliminary and adjusted rules, where a series of variables or conditions are taken into account. The third step is the **compilation** of results which serve to build the forest fire information system (SIIF), establish the vulnerability of the forest and calculate a fire's intensity or rate of spread. The last step is **validation**. The results are verified at the site and with reconnaissance flights. This work enables us to validate or invalidate the classification rules and even to establish new ones.

---

1 For this type of fuel, we found forest stands with the same structure as those of the C2 type in the Canadian FBP method. However, many species groups of the softwood-type cover were impossible to classify, since they neither have the desired structure, nor composition. We therefore grouped them together in the *C-2 other (C-2a)* fuel type, as opposed to the "true" class C-2 (*C-2v*). When adding all C-2 areas without distinction, over 77% are classified as C-2a.

2. This system is based on dividing up the territory into raster cells. A raster cell is a territorial unit measuring 15 seconds of longitude by 15 seconds of latitude. Its average area is 14 ha.

## About validation of results

When developing a classification method, always ensure that the results obtained by applying established rules conform to what exists in the field. Otherwise, the method should be revised, at least partially.

Our results were validated from the air, since this technique is closest to aerial photography (vertical view of forest stands and fuel characteristics). In addition, during site visits, the structure of the forest cover was examined so we could determine the herbaceous, shrub and tree strata composition. We took photographs from both the air and ground to confirm our findings for the forest stands and fuel types observed.

To validate the new forest stand classification, we covered several management units overlapping more than one ecological region (four zones were flown over, Figure 1). This enabled us to test the method and see how reliable it was before applying it to all of Québec. The reconnaissance flights and validation process were only carried out for species groups with significant presence. We did not validate or locate strata that were rare in Québec forests.

The species groups whose name was not changed between second and third ten-year forest survey program were not visited. They were therefore subjected to the same classification rules as those established with the second survey program. This includes almost all deciduous forest stands and certain softwood forest stands.

The new classification method (third ten-year forest survey program) was validated over several years. In 2002, we visited mixedwood forest stands, softwood plantations with black spruce, white spruce, Norway spruce, white pine and red pine; dry bare land with lichen (in southern part of territory); black spruce stands with lichen and mixedwood or deciduous forest stands invaded by alder or non-commercial hardwoods. In 2003, we continued examining mixedwood forest stands, dry bare land with lichen and spruce stands with lichen. We looked at burned areas on bedrock, steep slope or till, over 20 years old and under 20 years old. In 2004, we completed the classification of mixedwood forest stands. We analyzed regeneration after cutting in jack pine. We flew over burned areas, dry bare land with various deposits, and bare land and semi-bare land in the ecological region west of Mistassini lake. In 2005, we finished analyzing dry bare lands with lichen, cutting with protection of high regeneration or small merchantable stems, and young 10-year-old jack pine stands. We explored cedar and larch stands both at dry and wet sites. We classified forest stands meeting the criteria of type "C2 true", but for wet sites. Lastly, we analyzed spruce stands with black spruce or fir, and fir stands with balsam fir or black spruce with densities over 60% and heights over 17 m. We did not evaluate any stands in 2006. In 2007, we completed the rest of the third survey data by verifying the presence of grass and shrubs in very young plantations and evaluating regenerated burned areas, non-regenerated wildlands, non-regenerated areas that were cut with protection of regeneration and whose cover before disturbances was not determined and young deciduous or mixedwood forest stands on wildlands.

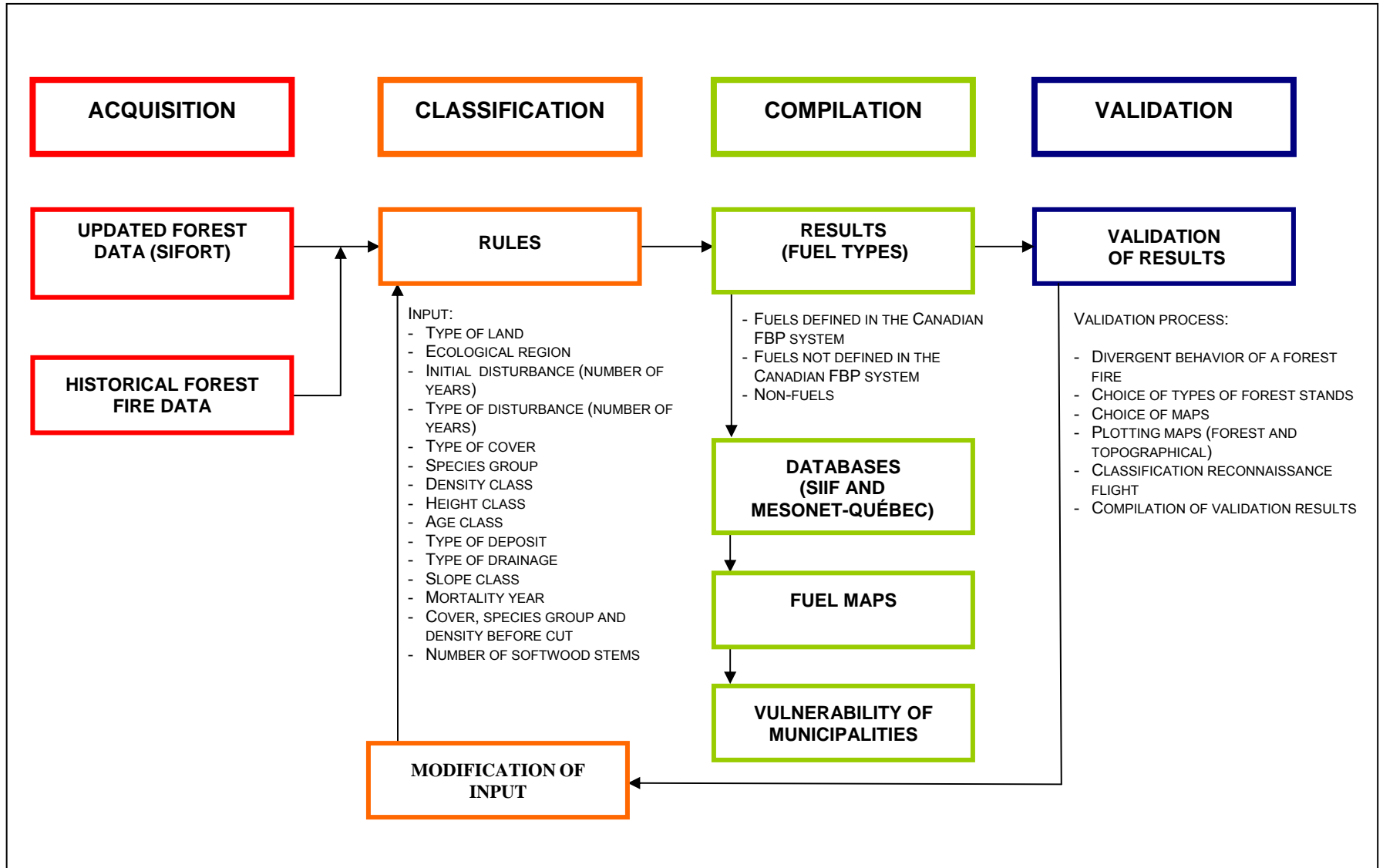


Figure 2 - Fuel classification process

## 5. Classification Rules

The classification of forest stands is primarily based on forest stratification established by photo-interpreters (cover, species groups and sub-groups, density classes, height classes, age classes, disturbances, initial disturbance, surface deposits, drainage classes, ecological types and types of terrain). For more accurate results, it is necessary to take into account forest stand tables and the territory separated into ecological regions.

According to the data of the third ten-year forest survey program, there are 39 species groups with deciduous cover (15 in plantations), 251 with mixedwoods (111 in plantations) and 210 with softwoods (133 in plantations). To better classify some species groups, certain additional variables are used, such as the **ratio of softwoods** (number of softwood stems in relation to total number of stems), **mortality** (number of years passed since an insect epidemic destroyed a stand) and **age** (number of years or period passed since the last disturbance other than an insect infestation).

It should be pointed out that it takes 10 to 20 years for survey data to be updated and that during this time, forest stands evolve considerably. To take this into account, we introduced the notion of fuel type evolution in the classification.

In all, some 109 rules were established to ensure forest fuels were classified properly. Classification rules that were established for a given stratum apply to all territory.

### 5.1 Validation Results

#### 5.1.1 Mixedwood species groups

This type of cover was completely revised during the third ten-year forest survey program. However, the percentage of softwoods (25 to 75%) characterizing these groups was not modified. Two groups are possible and are differentiated by: deciduous dominance and softwood dominance.

The way the groups are named was also modified. For forest stands over 7 m high, the first letter or the two first letters in the name designate the dominant species of the group (e.g. EBB for spruce stand with white or gray birch and BBE<sup>1</sup> for white birch stand with black or red spruce). Forest stands from 4 to 7 m high that are not associated with any species group, but are composed of deciduous and softwood species, are identified by the letters MR (softwood-dominant mixedwood species), MF (deciduous-dominant mixedwood species) and MX (mixedwood species regenerating).

For the second ten-year forest survey program, we had already established different softwood ratios corresponding to three modifiers, each associated with a percentage of softwoods: 35, 55 and 70% (M-1/35, M-1/55 and M-1/70). It is important to specify that fuel type **M-1** becomes **M-2** when leaves appear.

Only species groups that are well represented in the four zones flown over (west, east, centre and Lower St. Lawrence-Gaspé Peninsula) were verified (Table 1). We included strata with the same composition, or similar to it, but which were not as well represented.

---

<sup>1</sup> Letters correspond to French names of stands

All mixedwood species groups with white pine, red pine or Eastern hemlock as a dominant species, or white pine or red pine as a companion species were classified as **C-5**, regardless of the softwoods ratio. Shrub and tree strata are not often present. Their association with deciduous tree species differentiate them from other mixedwood groups.

The majority of deciduous-dominant mixedwood species groups belong to types **M-1/35** or **M-1/55**, depending on the softwoods ratio. As a result, a deciduous-dominant stratum will be classified as M-1/35 provided that the ratio of softwoods is under 44%, otherwise it will be M-1/55 (Pelletier et al., 1995, 1999 and 2001). When the area was flown over, we identified ten softwood-dominant mixedwood strata (RBJ-, RBJ+, RFT, CBJ-, CBJ+, REO, RER, RFH, RFI and RPE) that meet the same rules.

The other softwood-dominant species groups, except those stated previously, were mostly classified as **M-1/70**. However, when the softwood ratio was under 60%, the stand was classified as **M-1/55** (Pelletier, et al., 1995, 1999 and 2001).

Lastly, mixedwood groups regenerating designated as MF were classified as **M-1/35**. Those called MR were classified **M-1/70**, whereas MX remained in the generic class **M-1/55**.

**Table 1** - Reconnaissance flight results for mixedwood species groups

Species groups	Number of raster cells <sup>1</sup>	Species group flow over	Fuel type	Total number of raster cells
BB1R	4,549	BB1S	M-1/35	14,308
BB1S	9,759			
BBBBE	18,549	BBBBE	M-1/35	19,615
BBBBG	68			
BBBBPG	867			
FIPEE	98			
FIPEPG	33			
BBBBR	14,706	BBBBR	M-1/35	22,738
BBPER	6,716			
FIBBR	694			
FIPER	622			
BBBBS	34,783	BBBBS	M-1/35	41,833
BBPES	5,904			
FIBBS	678			
FIPES	468			
BB1E	791	BBE	M-1/55	28,258
BB1PG	38			
BBE	16,223			
BBPEE	4,816			
BBPEG	26			
BBPEPG	912			
BBPG	1,433			
FIBBE	261			
FIBBPG	16			
FIE	3,190			
FIPG	552			
BBR	26,867	BBR	M-1/35	26,867
BBS	22,243	BBS	M-1/55	22,243
BJ+C	2,281	BJR (+ and -)	M-1/35	61,747
BJ+PB <sup>2</sup>	331			
BJ+PR	9			
BJ+PU	686			
BJ+R	28,664			
BJ-C	1,168			
BJ-PB <sup>2</sup>	294			
BJ-PR	3			
BJ-PU	503			
BJ-R	27,808			
EBB	36,793	EBB	M-1/70	41,883
EFI	4,781			
GBB	248			
GFI	11			
GPE	50			

**Table 1** - Reconnaissance flight results for mixedwood species groups (cont'd)

Species group	Number of raster cells <sup>1</sup>	Species group flown over	Fuel type	Total number of raster cells
EOR	27,535	EOR	M-1/35	34,600
ERR	7,065			
EPE	13,482	EPE	M-1/70	13,482
FIR	11,487	FIR	M-1/35	11,487
FIS	7,799	FIS	M-1/35	7,799
FHR	1,668			
FTP <sup>2</sup>	3,312	FTR	M-1/35	15,753
FTPR	62			
FTR	10,711			
PB+BB	1,707			
PB+BJ	264			
PB+FI	1,140			
PB+FT	2,535			
PB+PE	1,823			
PB-BB	714			
PB-BJ	214			
PB-FI	455			
PB-FT	593			
PB-PE	393			
PR+BB	76	PBFT (+ and -)	C-5	11,685
PR+BJ	6			
PR+FI	54			
PR+FT	26			
PR+PE	67			
PR-BB	21			
PR-BJ	4			
PR-FI	8			
PR-FT	28			
PR-PE	28			
PUBJ-	660			
PUBJ+	869			
PE1E	270			
PE1PG	10			
PEBBE	5,609	PEE	M-1/35	24,222
PEBBG	31			
PEBBPG	1,354			
PEE	11,751			
PEPEE	5,124			
PEPEG	73			
BB1PB	21			
BBBBPB	32			
BBPB	1,558	PEPB	C-5	6,008
BBPEPB	7			
BBPR	23			

**Table 1** - Reconnaissance flight results for mixedwood species groups (cont'd)

Species group	Number of raster cells <sup>1</sup>	Species group flown over	Fuel type	Total number of raster cells
FIBBPB	15			
FIPB	1,160			
FIPEPB	30			
FIPR	54			
PE1PB	10			
PEBBPB	3			
PEPB	3,002			
PEPEPB	7			
PEPR	86			
PEPEPG	1,576	PEPG	M-1/35	4,996
PEPG	3,420			
BB1PR	9	PER	M-1/55	26,299
BBBBPR	8			
BBPEPR	8			
PE1R	1,085			
PE1PR	14			
PEBBR	7,342			
PEBBPR	28			
PEPEPR	25			
PEPER	4,071			
PER	13,709			
PE1S	1,859	PES	M-1/35	24,920
PEBBS	5,772			
PEPES	4,173			
PES	13,116			
PGBB	3,711	PGPE	M-1/70	10,371
PGFI	1,408			
PGPE	5,252			
RBB	26,162	RBB	M-1/70	26,162
RBJ-	10,210	RBJ (+ and -)	M-1/55 and M-1/35	20,049
RBJ+	5,635			
RFT	4,204			
CBJ-	1,127	REO	M-1/55 and M-1/35	16,796
CBJ+	637			
REO	12,688			
RER	879			
RFH	1,465			
RFI	8,898	RFI	M-1/55 and M-1/35	8,898
RPE	7,168	RPE	M-1/35 and M/1-55	7,168
SBB	48,433	SBB	M-1/55	61,230
SFI	6,271			
SPE	6,526			
MF <sup>3</sup>	18,561	MF	M-1/35	18,561
MR <sup>3</sup>	70,811	MR	M-1/70	70,811
MX <sup>3</sup>	3,048	MX	M-1/55	3,048

1. In Québec, the average area of a raster cell is 14 ha.

2. BJ+Pb, BJ-PB and FTPB are identified with other mixedwood stands containing white pine.

3. Species group added when the forest database was updated.

### 5.1.2 Plantations

During the classification of forest stands in 2001 (second ten-year forest survey program), we examined plantations with jack pine, black spruce, Norway spruce, red pine, white pine and white spruce. During the third survey, we flew over forest land to validate these same species and we focused on the ecological sub-region when data were compiled. We compared results with those obtained previously, which made it possible to better classify the forest stands (Table 2).

Due to the small number of hardwood (deciduous) plantations, they were not flown over. They were assigned the rules of the previous classification method. In the case of mixedwood plantations, the vast majority are softwood plantations invaded by various deciduous species. Other than those containing white pine and red pine, these plantations were not studied. They were simply classified using the rules of the previous survey.

**Table 2** - Reconnaissance flight results for softwood plantations

Species	Ecological Sub-Region	Age Class	Fuel Type
Jack pine or Scotch pine <sup>1</sup>	All	8 years and under	O-1a/65
		4 to 7 m high	C-2
		over 7 m high	C-3
Red pine <sup>2</sup>	All	8 years and under	O-1a/65
		from 9 to 24 years	M-1/35
		25 years and over	C-6
White pine <sup>2</sup>	All	8 years and under	O-1a/65
		Over 8 years	C-5
Norway spruce <sup>2</sup>	Boreal forest	9 years and under	O-1a/65
		From 10 to 20 years	M-1/55
		21 years and over	C-2 other
	Mixedwood forest	8 years and under	O-1a/65
		From 9 to 19 years	M-1/55
		20 years and over	C-6
White spruce or red spruce <sup>2</sup>	Boreal forest	9 years and under	O-1a/65
		From 10 to 20 years	M-1/55
		21 years and over	C-2 other
	Mixedwood forest	8 years and under	O-1a/65
		From 9 to 16 years	M-1/55
		17 years and over	C-2 other
Black spruce <sup>2,3</sup>	Boreal forest	12 years and under	O-1a/65
		13 years and over	C-2 other
	Mixedwood forest	8 years and under	O-1a/65
		From 9 to 16 years	M-1/55
		17 years and over	C-2 other

1. These species dominate in the plantation (e.g. PIG or PIGEPO) or are present as companion species (e.g. PIBPIG).

2. This species dominates in the plantation or is a companion species.

3. Larch, fir and cedar plantations follow the same rules as those for black spruce plantations.

### 5.1.3 Forest stands affected by mortality

In Québec, tree mortality due to insects occurred mainly during the 1970s and 1980s. More recently, forests in the North Shore region experienced an episode of severe defoliation, followed by high mortality rates in 1999 and 2000.

During the first classification project (in 1995), for sectors and forest stands where the mortality year was unknown, we established a reference mortality year for each management unit. This information was taken from a MRNF historical database on insect epidemics (spruce budworm and hemlock looper). However, certain deficiencies were found afterwards. This method did not take altitude and latitude into account, particularly when the management unit occupied an area that extended from south to north. In 2003, areas affected by moderate to severe defoliation between 1967 and 2003 were compiled once again, but this time based on ecological sub-regions. These sub-regions are more homogenous than management units and therefore data are more representative of mortality (Table 3).

In the new forest stand classification method, when the MRNF database did not contain defoliation information for a particular sector, the year 1978 was chosen as the reference mortality year (Table 4). This information was used to classify forest stands when mortality (severe epidemics<sup>1</sup>) was reported in the SIFORT database. The number of years passed since the mortality occurred (variable: *mortality*) can thus be calculated.

We did not modify any other classification rule for forest stands affected by mortality. Rules that were applied to the data from the second ten-year forest survey program remain valid. Modifiers associated with the type correspond to the percentage of dead balsam fir, i.e. 25, 50 or 75% (M-3/25, M-3/50 and M-3/75). It is also worth mentioning that even if only the fuel type **M-3** is presented, it becomes **M-4** when leaves appear.

---

1. During a severe epidemic (ES), when over 75% of the basal area of the stand is destroyed, the disturbance is called an "initial disturbance," since it initiates a new stand. If the basal area is reduced only by 25% to 75%, the epidemic is deemed to be mild (EL).

**Table 3 - Percentage of areas affected by moderate or severe defoliation by ecological sub-region from 1967 to 2003**

Sub-region	1967	1968	1969	1970	1971	1972	1973	1974	1975	1976	1977	1978	1979	1980	1981	1982	1983	1984	1985	1986	1987	1988	1989	1990	1991	1992	1993	1994	1995	1996	1997	1998	1999	2000	2001	2002	2003	
1aT	0	9	6	2	2	4	2	3	<b>1</b>	0	0	0	0	0	0	0	0	0	0	0	0	0	0	0	0	0	1	2	2	3	2	2	1	1	4	1	1	
2aT	0	44	48	25	24	48	13	40	<b>45</b>	0	1	1	0	0	0	0	0	0	0	0	0	0	0	0	0	3	2	9	14	18	19	21	33	27	39	5	14	
2bT	1	13	0	0	1	2	1	16	<b>23</b>	3	2	4	4	1	0	2	3	5	1	0	0	0	0	0	0	0	0	1	0	0	1	1	0	1	1	1	1	
2cT	0	0	0	0	0	0	0	0	<b>60</b>	1	6	8	4	1	0	2	1	1	0	0	0	0	0	0	0	0	0	0	0	0	0	0	0	0	0	0	0	
3aM	0	58	77	69	80	84	58	<b>76</b>	22	9	5	3	2	2	7	5	2	3	0	0	0	0	0	0	0	0	2	3	4	4	3	3	6	0	0	1		
3aS	0	0	3	6	21	25	26	25	59	53	35	33	47	90	<b>26</b>	2	5	0	0	0	0	0	0	0	0	0	0	0	0	0	0	0	0	0	0	0	0	
3aT	0	10	65	58	80	85	67	55	<b>32</b>	16	4	3	6	33	<b>2</b>	1	2	0	0	0	0	0	0	0	0	0	0	0	0	0	0	0	0	0	0	0	0	
3bM	0	1	1	3	9	45	24	44	<b>72</b>	0	1	1	1	1	0	0	0	0	0	0	0	0	0	0	0	0	0	0	0	0	0	0	0	1	3	0	1	
3bT	0	0	16	24	60	100	40	94	<b>87</b>	2	5	5	5	5	1	1	0	1	0	0	0	0	0	0	0	0	0	0	0	0	0	0	0	0	0	0	1	
3cM	2	7	0	0	0	2	0	21	<b>80</b>	0	0	0	0	0	0	2	7	9	1	5	1	0	0	0	0	0	0	0	0	0	0	0	0	0	1	1	1	
3cS	0	0	0	5	6	76	99	66	86	0	0	4	4	10	2	22	65	48	46	<b>51</b>	1	0	0	0	0	0	0	0	0	0	0	0	0	0	0	0	0	
3cT	0	2	0	2	3	27	36	79	96	1	1	2	1	4	5	30	66	65	57	<b>46</b>	7	1	0	0	0	0	0	0	0	0	0	0	1	1	1	1	1	
3dM	0	0	0	1	0	0	0	6	100	49	54	65	45	33	33	11	<b>50</b>	10	0	0	0	0	0	0	0	0	0	0	0	0	0	1	1	1	1	1	1	
3dS	0	0	0	0	0	0	0	0	100	69	66	65	57	56	52	11	<b>27</b>	3	0	0	0	0	0	0	0	0	0	0	0	0	0	0	0	0	0	0	0	
3dT	0	0	0	0	0	0	2	17	100	82	92	97	87	78	85	76	98	<b>29</b>	2	12	0	0	0	0	0	0	0	0	0	0	0	0	0	0	0	0	0	
4aT	0	0	0	0	4	3	8	36	68	57	38	18	43	41	<b>51</b>	14	3	3	1	0	0	0	0	0	0	0	0	0	0	0	0	0	0	0	0	0	0	
4bM	0	0	37	39	88	98	52	63	<b>65</b>	10	4	4	4	44	9	5	6	0	1	0	0	0	0	0	0	0	0	0	0	0	0	0	0	0	0	0	0	
4bS	0	0	0	5	11	89	87	69	35	12	4	2	9	88	<b>60</b>	4	2	3	0	0	0	0	0	0	0	0	0	0	0	0	0	0	0	0	0	0	0	
4bT	0	0	11	12	57	81	67	70	38	26	14	14	22	94	<b>38</b>	6	3	3	0	0	0	0	0	0	0	0	0	0	0	0	0	0	0	0	0	0	0	
4cM	0	0	0	0	0	0	7	99	100	10	25	44	44	33	47	45	83	76	100	<b>68</b>	0	0	0	0	0	0	0	0	0	0	0	0	0	0	0	0	0	0
4cT	0	0	0	1	13	65	61	71	93	22	3	7	6	62	64	51	72	47	58	<b>35</b>	1	0	0	0	0	0	0	0	0	0	0	0	0	0	0	0	0	0
4dM	0	0	0	0	0	0	13	30	81	64	39	56	60	51	58	37	55	<b>19</b>	10	7	0	0	0	0	0	0	0	0	0	0	0	0	0	0	0	0	0	0
4dT	0	0	0	2	5	2	13	86	91	99	88	67	47	65	93	83	100	<b>83</b>	17	1	0	0	0	0	0	0	0	0	0	0	0	0	0	0	0	0	0	0
4eT	0	0	0	0	3	1	3	29	39	23	11	15	10	3	15	10	35	<b>22</b>	3	0	0	0	0	0	0	0	0	0	0	0	0	0	0	2	3	4	6	
4fM	0	0	0	22	68	37	15	70	95	49	67	96	87	44	53	83	<b>93</b>	2	3	0	0	0	0	0	0	0	0	0	0	0	0	0	0	0	0	0	0	0
4fS	0	0	0	0	0	0	13	4	97	55	73	59	32	49	93	85	93	26	6	32	34	50	<b>60</b>	2	0	0	0	0	0	0	0	0	0	0	0	0	0	0
4fT	0	0	0	5	16	11	10	38	79	65	71	70	69	59	71	79	87	<b>23</b>	5	9	2	2	3	0	0	0	0	0	0	0	0	0	0	0	0	0	0	0
4gT	0	0	0	0	0	3	9	82	97	41	50	63	49	39	77	94	94	41	5	5	8	10	29	19	<b>13</b>	2	0	0	0	0	0	0	0	0	0	0	0	0
4hT	0	0	0	0	0	0	1	1	52	88	72	56	47	57	99	98	97	63	21	<b>17</b>	1	0	11	7	3	1	0	0	0	0	0	0	0	0	0	0	0	0
5aT	0	0	0	0	1	4	9	34	35	24	30	18	23	23	<b>27</b>	4	5	5	1	0	0	0	0	0	0	0	0	0	0	0	0	0	0	0	0	0	0	
5bT	0	0	0	0	8	43	47	80	32	24	4	2	4	28	<b>39</b>	5	8	7	6	0	0	0	0	0	0	0	0	0	0	0	0	0	0	0	0	0	0	
5cM	0	0	0	0	1	0	7	61	98	77	65	85	73	91	79	44	98	83	91	<b>33</b>	0	0	0	0	0	0	0	0	0	0	0	0	0	0	0	0	0	0
5cS	0	0	0	0	0	14	52	31	<b>64</b>	19	7	26	8	37	11	24	24	<b>19</b>	9	0	0	0	0	0	0	0	0	0	0	0	0	0	0	0	0	0	0	
5cT	0	0	0	0	3	60	63	62	62	41	4	14	5	46	47	24	40	39	<b>45</b>	8	0	0	0	0	0	0	0	0	0	0	0	0	0	0	0	0	0	

The underlined figure in bold indicates the reference mortality year.

**Table 3 - Percentage of areas affected by moderate or severe defoliation by ecological sub-region from 1967 to 2003 (continued)**

Sub-region	1967	1968	1969	1970	1971	1972	1973	1974	1975	1976	1977	1978	1979	1980	1981	1982	1983	1984	1985	1986	1987	1988	1989	1990	1991	1992	1993	1994	1995	1996	1997	1998	1999	2000	2001	2002	2003	
5dM	0	0	0	0	10	6	32	68	96	95	93	85	61	44	85	48	95	<b>59</b>	14	12	0	0	0	0	0	0	0	0	0	0	0	0	0	0	0	0	0	
5dT	0	0	0	0	1	0	9	58	71	81	75	70	7	15	16	18	35	29	<b>31</b>	14	0	0	0	0	0	0	0	0	0	0	0	0	0	0	0	0	0	
5eS	0	0	0	1	0	0	5	9	89	100	100	92	12	18	25	17	38	18	<b>47</b>	10	0	0	0	0	0	0	0	0	0	0	0	0	0	0	0	0	0	
5eT	0	0	0	0	0	1	12	56	89	94	88	78	39	65	50	45	92	72	69	<b>35</b>	0	0	0	0	0	0	0	0	0	0	0	0	0	0	0	0	0	
5fS	0	0	0	0	1	0	5	93	84	97	100	100	24	54	23	50	62	39	<b>26</b>	3	0	0	0	0	0	0	0	0	0	0	0	0	0	0	0	0	0	
5fT	0	0	0	0	0	0	3	96	100	100	85	93	64	86	89	94	100	89	<b>70</b>	0	0	0	0	0	0	0	0	0	0	0	0	0	0	0	0	0	0	
5gT	0	0	0	0	0	0	0	74	63	89	87	39	12	20	31	66	71	41	57	72	50	11	14	18	<b>13</b>	2	0	0	0	0	0	0	0	0	0	0	0	0
5hT	0	0	0	0	0	0	13	65	93	75	64	40	28	54	89	84	86	51	30	48	45	46	54	47	<b>20</b>	6	0	0	0	0	0	0	0	0	0	0	0	0
5iS	0	0	0	0	0	0	0	0	31	100	82	35	11	15	68	91	94	41	30	62	32	24	61	64	<b>52</b>	9	0	0	0	0	0	0	0	0	0	0	0	0
5iT	0	0	0	0	0	0	3	41	75	95	67	10	6	52	88	96	85	37	38	53	49	56	59	64	<b>26</b>	9	0	0	0	0	0	0	0	0	0	0	0	0
5jT	0	0	0	0	0	0	12	6	59	60	69	2	5	28	50	41	<b>72</b>	12	2	3	7	3	0	0	0	0	0	0	0	0	0	0	0	0	0	0	0	
6aT	0	0	0	0	0	0	2	30	15	26	44	<b>29</b>	0	0	6	0	0	0	0	0	0	0	0	0	0	0	0	0	0	0	0	0	0	0	0	0	0	
6bT	0	0	0	0	0	0	0	0	0	0	0	<b>0</b>	0	0	0	0	0	0	0	0	0	0	0	0	0	0	0	0	0	0	0	0	0	0	0	0	0	
6cT	0	0	0	0	0	2	1	57	4	9	18	<b>10</b>	0	0	2	0	0	0	0	0	0	0	0	0	0	0	0	0	0	0	0	0	0	0	0	0	0	
6dS	0	0	0	0	0	0	0	0	0	0	4	<b>0</b>	0	0	0	0	0	0	0	0	0	0	0	0	0	0	0	0	0	0	0	0	0	0	0	0	0	
6dT	0	0	0	0	0	0	0	2	0	6	11	<b>0</b>	0	0	0	0	0	0	0	0	0	0	0	0	0	0	0	0	0	0	0	0	0	0	0	0	0	
6eT	0	0	0	0	0	0	1	78	25	33	48	<b>47</b>	1	8	1	0	1	0	1	0	0	0	0	0	0	0	0	0	0	0	0	0	0	0	0	0	0	
6fT	0	0	0	0	0	0	0	45	0	10	25	<b>24</b>	0	0	0	0	0	0	0	0	0	0	0	0	0	0	0	0	0	0	0	0	0	0	0	0	0	
6gT	0	0	0	0	0	0	0	1	7	18	36	<b>22</b>	0	1	0	0	0	0	0	0	0	0	0	0	0	0	0	0	0	0	0	0	0	0	0	0	0	
6hT	0	0	0	0	0	0	0	26	43	93	89	<b>63</b>	3	3	1	2	3	3	4	4	1	1	0	0	1	0	0	0	0	0	0	0	0	0	0	0	0	
6iS	0	0	0	0	0	0	0	0	0	28	68	<b>57</b>	0	0	0	0	0	0	0	0	0	0	0	0	0	0	0	0	0	0	0	0	0	0	0	0	0	0
6iT	0	0	0	0	0	0	0	10	14	77	<b>89</b>	9	0	0	0	1	5	2	2	8	6	1	1	1	0	0	0	0	0	0	0	0	0	0	0	0	0	0
6jS	0	0	0	0	0	0	0	0	10	39	57	<b>25</b>	0	0	0	1	2	0	0	6	3	0	0	0	0	0	0	0	0	0	0	0	0	0	0	0	0	0
6jT	0	0	0	0	0	0	0	4	40	71	<b>18</b>	0	3	6	9	8	0	1	4	5	0	0	0	0	0	0	0	0	0	0	0	0	1	3	6	1	0	0
6kT	0	0	0	0	0	0	0	0	0	0	<b>77</b>	0	0	0	0	0	0	0	0	0	0	0	0	0	0	0	0	0	0	0	0	0	0	0	0	0	0	0
6lT	0	0	0	0	0	0	0	0	0	0	<b>49</b>	5	0	0	0	0	0	0	0	0	0	0	0	0	0	0	0	0	0	0	0	0	0	0	0	0	0	0
6mS	0	0	0	0	0	0	0	0	0	0	35	6	6	0	62	18	<b>25</b>	0	0	0	0	0	0	0	0	0	0	0	0	0	0	0	0	11	9	0	0	0
6mT	0	0	0	0	0	0	0	6	31	<b>71</b>	16	4	4	11	13	6	0	0	0	0	0	0	0	0	0	0	0	0	0	0	0	0	1	2	0	0	0	
6nT	0	0	0	0	0	0	0	0	0	0	26	<b>21</b>	0	6	10	13	6	0	0	0	0	0	0	0	0	0	0	0	0	0	0	0	13	15	2	2	0	0
6qT	0	0	0	0	0	0	0	0	0	0	<b>0</b>	0	0	0	0	0	0	0	0	0	0	0	0	0	0	0	0	0	0	0	0	0	0	0	0	0	0	0
6rT	0	0	0	0	0	0	0	0	0	0	<b>0</b>	0	0	0	0	0	0	0	0	0	0	0	0	0	0	0	0	0	0	0	0	0	0	0	0	0	0	0

The underlined figure in bold indicates the reference mortality year.

**Table 4** - Reference mortality year by ecological sub-region

Ecological sub-region	Reference mortality year	Ecological sub-region	Reference mortality year
1aT	1975	5eS	1985
2aT	1975	5eT	1986
2bT	1975	5fS	1985
2cT	1975	5fT	1985
3aM	1974	5gT	1991
3aS	1981	5hT	1991
3aT	1975	5iS	1991
3bM	1975	5iT	1991
3bT	1975	5jT	1983
3cM	1975	5kT	1978
3cS	1986	6aT	1978
3cT	1986	6bT	1978
3dM	1983	6cT	1978
3dS	1983	6dS	1978
3dT	1984	6dT	1978
4aT	1981	6eT	1978
4bM	1975	6fT	1978
4bS	1981	6gT	1978
4bT	1981	6hT	1978
4cM	1986	6iS	1978
4cT	1986	6iT	1977
4dM	1984	6jS	1978
4dT	1984	6jT	1978
4eT	1984	6kT	1977
4fM	1983	6iT	1977
4fS	1989	6mS	1983
4fT	1984	6mT	1977
4gT	1991	6nT	1978
4hT	1986	6oT	1978
5aT	1981	6pT	1978
5bT	1981	6qT	1978
5cM	1986	6rT	1978
5cS	1984	7aT	1978
5cT	1985	7bT	1978
5dM	1984	7cT	1978
5dT	1985		

#### 5.1.4 Forest stands with lichen

The third ten-year forest survey program made it possible to specify certain characteristics of stands. One of these characteristics is the presence of lichen on the ground. Black spruce stands with lichen were therefore visited along with dry bare land and semi-bare land with lichen. According to our observations, only an abundance of lichen could have an effect on the stand's classification.

Black spruce stands with lichen were too dense and did not contain enough lichen to be classified in type **C-1**; they were therefore classified as **C-2**. However, the dry bare or semi-bare land represented type **C-1** well, except in the ecological sub-region west of Mistassini lake (6dT), where these sites correspond better to **C-2**.

#### 5.1.5 Non-regenerated burned areas

These areas had already been studied during the classification of the second ten-year forest survey program. This study did not make it possible to find indicators that would associate them to fuel types in the Canadian FBP system. Data from the third ten-year forest survey program provide the type of deposit, the drainage class and the slope class of non-regenerated burned areas.

To find out if these data would help classify these areas better, reconnaissance flights were done over several forest stands affected by fire. Two cases were considered: forest stands under 20 years old and those over 20 years old. In both cases, the slope and deposit conditions of the stands were looked at. It was concluded that, regardless of the slope and deposits, a burned area under 20 years of age has no or little regeneration. Burned areas under 20 years of age must therefore be classified as type **BR**, which is one of the fuels not defined in the Canadian FBP system. These burned areas can be affected by fire in varying degrees, including the year the fire occurred. Burned areas over 20 years old and located on a steep slope, thin deposit or bedrock are considered as type **M-1/35**. However, burned areas over 20 years old that still have no regeneration are classified as **DS**, another fuel type not defined in the Canadian FBP system.

#### 5.1.6 Cutting with protection of regeneration and soils

After getting data from the third ten-year forest survey program, new reconnaissance flights were done over sectors that were cut "with protection of regeneration and soils." The previous classification of these forest stands was still considered appropriate.

However, because the database was updated, new data were associated with "cutting with protection of small merchantable stems" and "cutting with protection of high merchantable stems". Large areas with these harvesting practices were located. In 2005, these sectors were flown over to validate our classification method. After having analyzed the results of this validation, it was concluded that these two types of initial disturbances should be considered as cutting with protection of regeneration and soils (CPRS). Our classification therefore remained unchanged.

### 5.1.7 Species groups dominated by 10-year jack pine regeneration and burned areas under 20 years old regenerated in jack pine

Every year, the SIFORT database is updated. During this update, data supplied by the MRNF's forest survey branch sometimes include new stand designations. As a result, the designation **PGPG** (pine stand with jack pine) in the 10-year age class was created. The information gathered during these reconnaissance flights allowed us to classify forest stands of this species group according to the following height classes for all ecological sub-regions:

Height class	Fuel type
2 m and under	<b>O-1a/65</b>
Over 2 m and under 7 m	<b>C-2</b>
7 m and over	<b>C-3</b>

### 5.1.8 Cedar and larch stands

These forest stands had been classified as non-fuels during the previous classification. We can now differentiate forest stands on organic deposits with poor to very poor drainage from those with good drainage on any other type of deposit. Both situations were compared. Despite this comparison, it was not possible to associate them with any fuel type in the Canadian FBP system. We therefore decided to distinguish them by type of drainage and type of deposit. As a result, cedar and larch stands that are on organic deposits or have poor to very poor drainage remain non-fuels and are associated with fuel type **DH**. Forest stands with good drainage were put in type **DS**, a fuel not defined in the Canadian FBP system.

### 5.1.9 Forest stands equivalent to C-3

During previous classification reconnaissance flights, we noticed that certain dense softwood forests composed of spruce and fir, in a stratum over 17 m high, looked like mature jack pine stands in terms of structure. A site visit was therefore paid to several of these stands. We noted four abundantly present species groups in the continuous boreal forest: spruce stand with black spruce, spruce stand with fir, fir stand with fir, and fir stand with spruce. However, only the spruce stand with black spruce had a structure similar to the pine stand and was classified as **C-3**. All other forest stands are part of the general type **C-2 other**.

### 5.1.10 Type C-2 *true* and drainage class

In the 1990s, we noted that several conditions were required for a spruce stand with black spruce or fir to belong to fuel type **C-2** in the Canadian FBP system. First the stand needed to be in the continuous boreal forest, have a density ranging from 25 to 60%, be composed of trees 7 to 17 m high, and belong to an age class above 70 or 90 years depending on the species group. Among all these conditions, none related to drainage.

Using data from the third ten-year survey program allowed us to assign a drainage class to each stand. To verify the effect of this new criteria on our classification, we flew over forest stands whose drainage class ranged from poor to very poor. After having compiled the results, we decided to modify the rules for inclusion in type **C-2 true**. In the new classification, it is necessary (in addition to previous criteria) that the drainage class of forest stands be different

from *poor to very poor*. As for forest stands that do not meet conditions, they were put together in type **C-2 other** (C2a).

#### 5.1.11 Regenerated or non-regenerated wildlands

During previous classification work, we chose to classify all wildlands (regenerated or not) as type **O-1**, which is associated with herbaceous species. Subsequently, it became necessary to specify the fuel sub-type, i.e. **O-1a** for flattened grasses in the spring and **O-1b** to identify standing grass that dried out before winter.

To validate the classification of these young forest stands, reconnaissance flights were done over a some of them in different areas. After compiling and analyzing the results, it was concluded that:

- Wildlands with mixedwood cover are in general well-established mixedwood stands. They were therefore classified together in type **M-1/55**;
- The other regenerated wildlands, those with a deciduous cover and those with a softwood cover, are still considered as open sites where grasses are abundant. To this group, we added seed orchards, since they all have the same structure, meaning that there are clusters of trees on a site mainly composed of herbaceous species accompanied by a few shrubs. We analyzed the different fuels defined in the Canadian FBP system to find an equivalent. These forest stands were assigned the fuel type **C-7**;
- Wildlands that are not regenerated are dominated by grasses. They were classified as type **O-1b** with 70% curing, regardless of the time during the fire season.

#### 5.1.12 Young softwood plantations with undetermined species

Over the years, reconnaissance flights were done over a number of plantations belonging to various age groups. After these flights, a scenario was established for classifying plantations according to species, height and number of years since planting. For the purposes of the method, forest stands whose initial species was known were always used.

To complete the work of the third ten-year survey program, we chose young softwood plantations whose species was not determined. Their young age puts them among fuel types of open sites. Field observations and classification of these fuels do not enable us to modify current rules. They will continue to be classified as **O-1a** or **O-1b** with a different and fixed percentage of curing, adapted to each case. In addition, during the season, there will be no change in fuel type and modifier.

## 6. Forest Fuel Classification Table (2009)

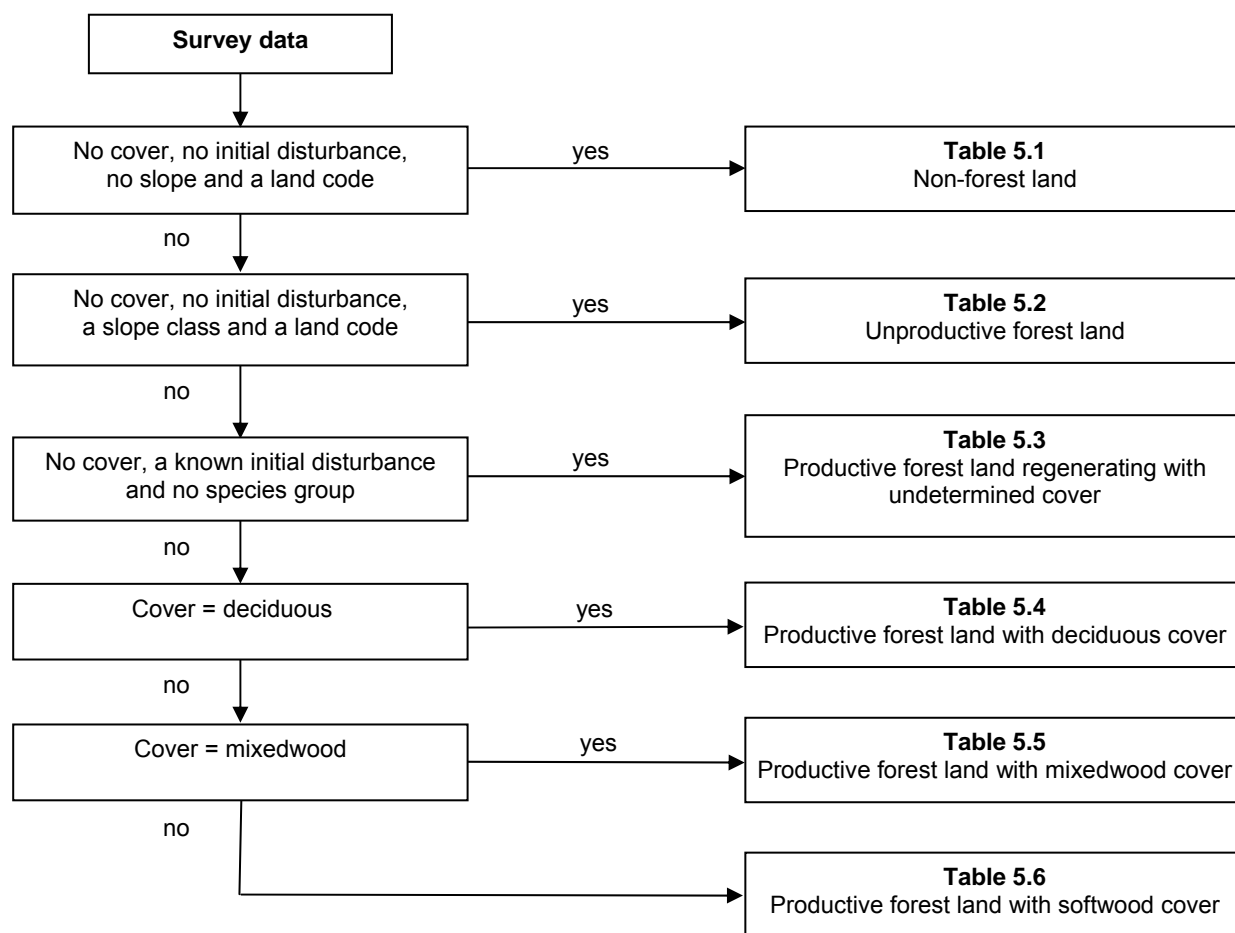
All results from reconnaissance flights over forest land served to modify and improve the forest fuel classification table. It was therefore possible to adjust classification rules.

The final classification table features 109 rules and uses data from stock tables and calculations regarding the number of years since an event occurred (Table 5). The table makes it possible to consider, if necessary, the ecological sub-region, the bioclimatic domain or vegetation sub-zone, the type of surface deposit, the drainage class and the slope class.

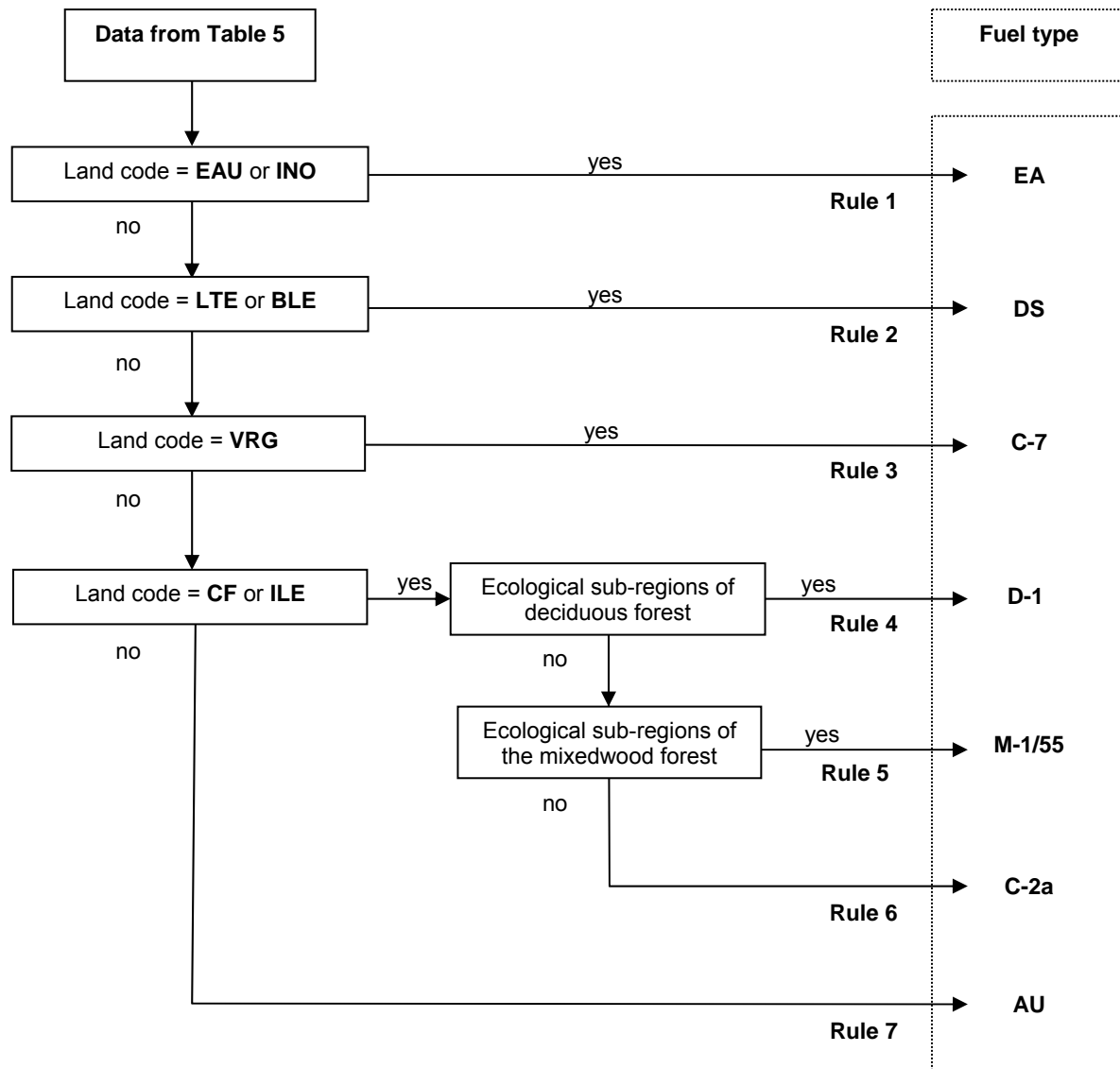
This new table is subject to change, since it is constantly necessary to modify certain classification rules to take into account new updates and validations. The flexibility of this tool is such that it can be improved continuously. For the sake of conciseness in the presentation of fuel types, types **M-2** and **M-4** do not appear in the following tables.

The description and content of all variables used in the table are found in the SIFORT user's guide (Pelletier, Dumont and Bédard, 2007). (In French)

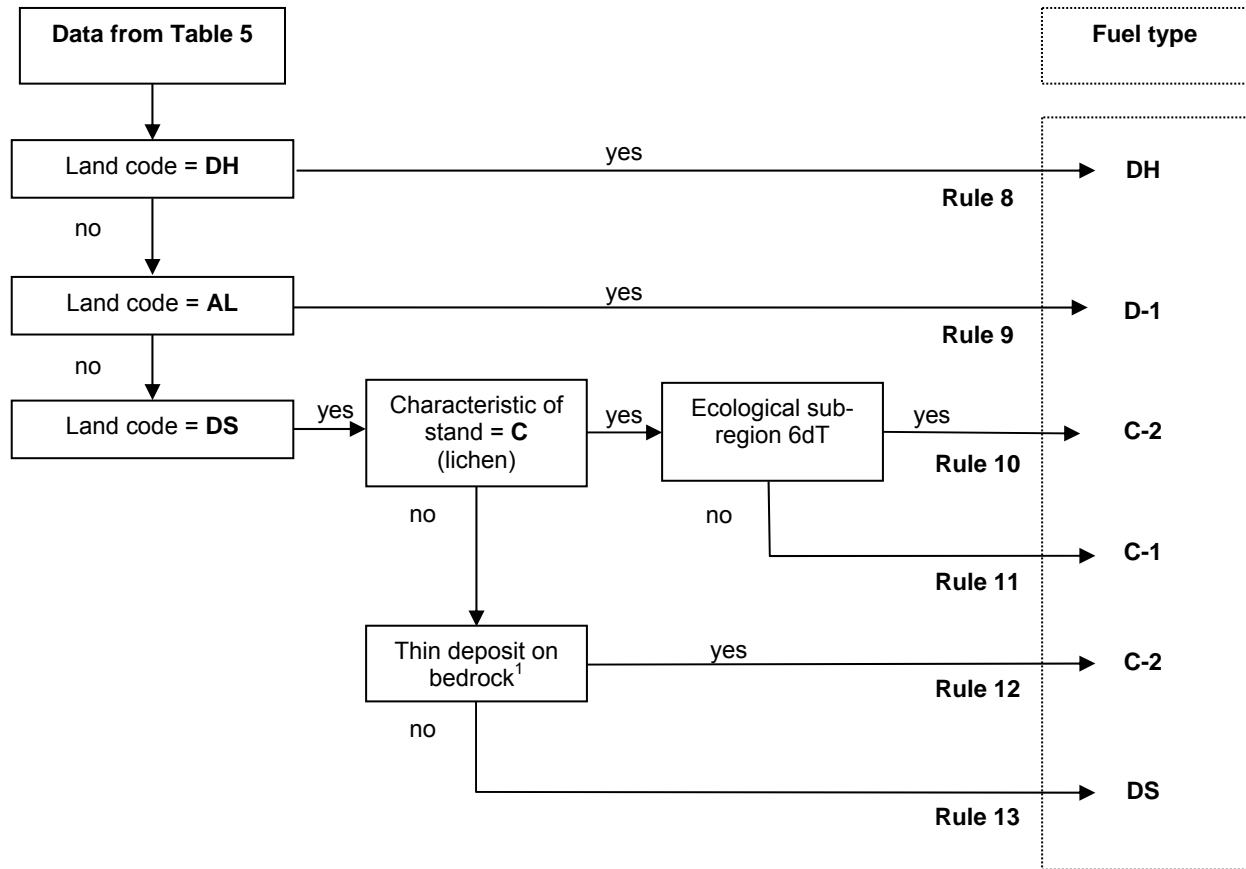
**Table 5** - Forest fuel classification table - Third ten-year forest survey program (2009)



**Table 5.1 - Non-forest land**

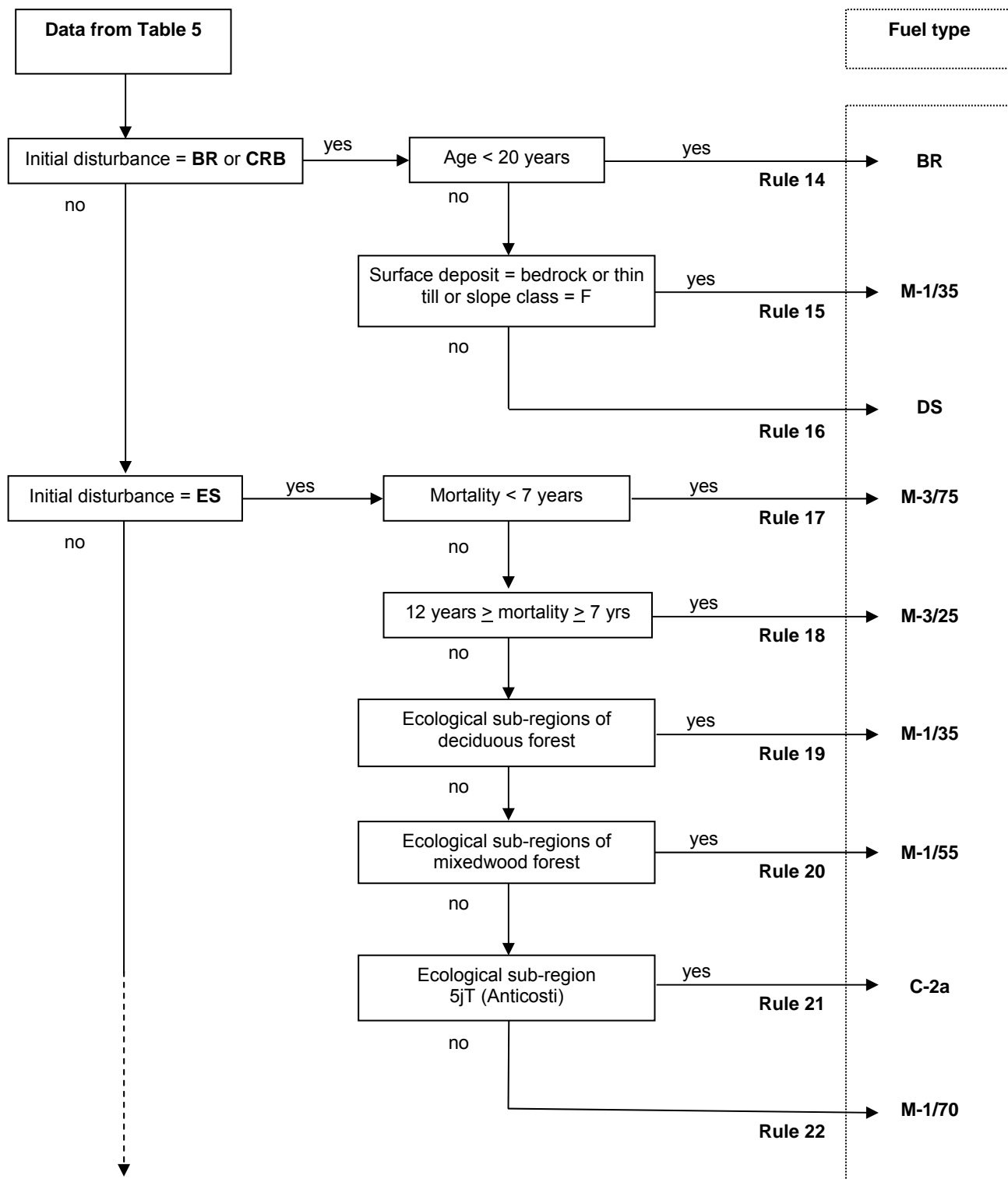


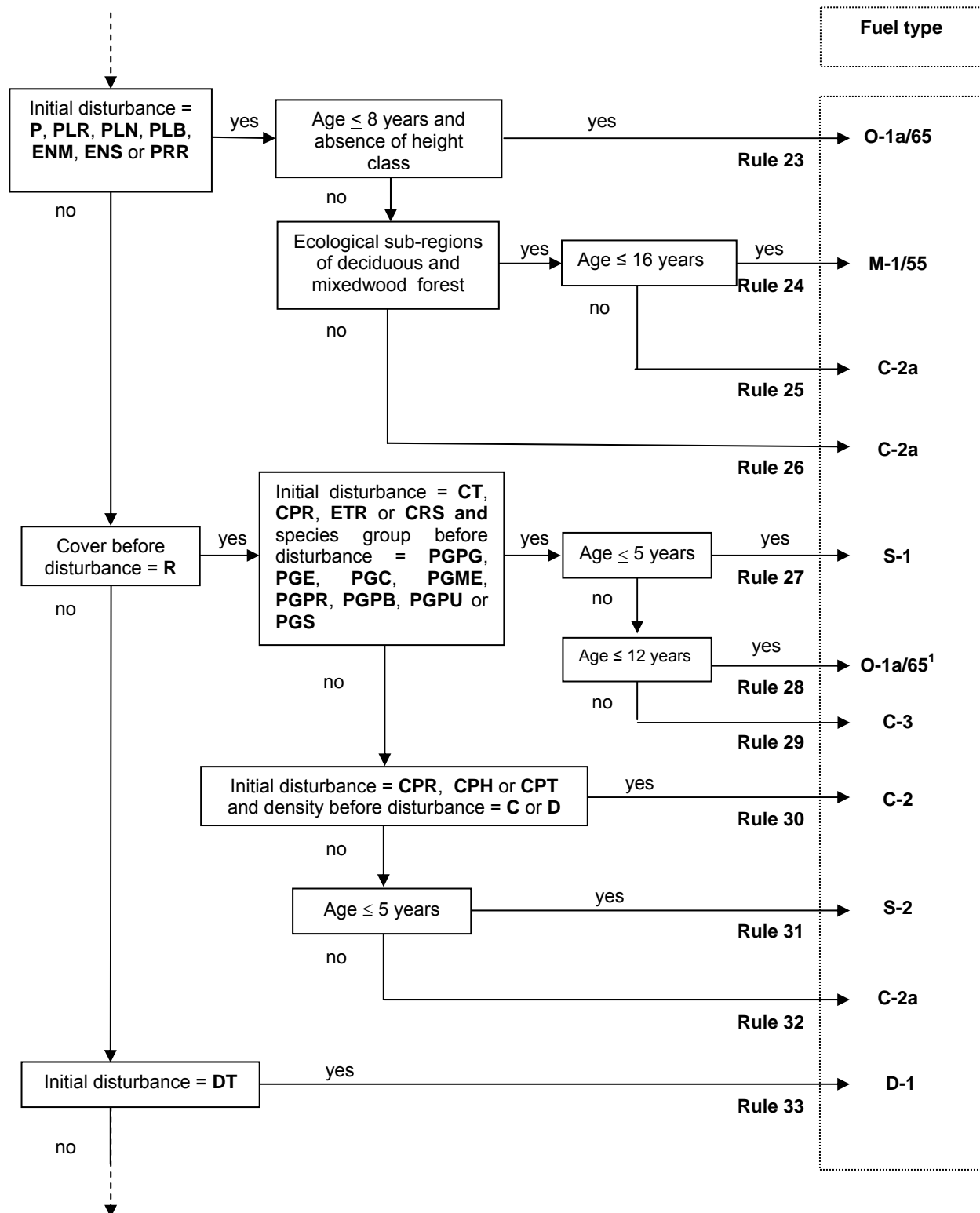
**Table 5.2 - Unproductive forest land**



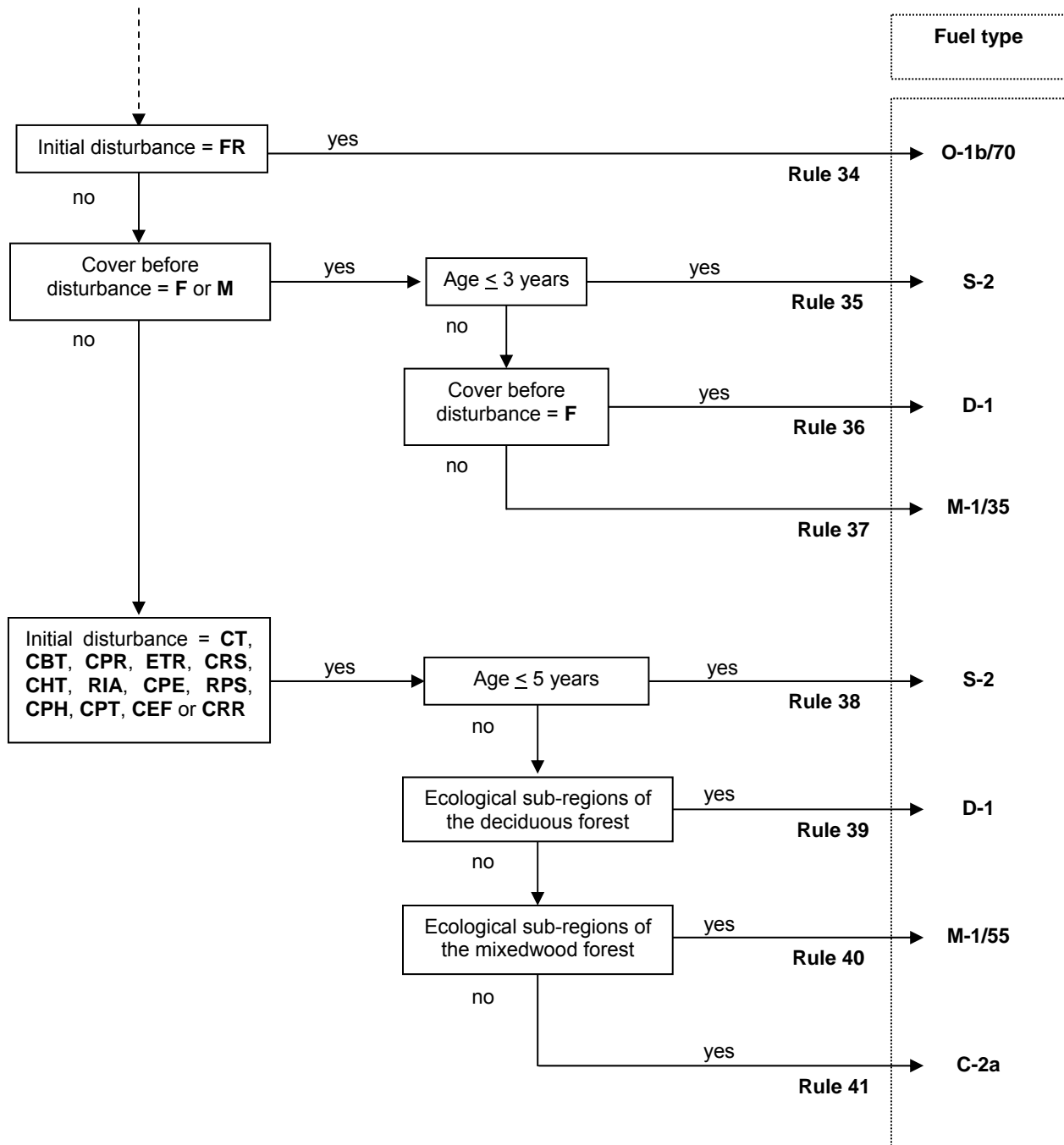
1. Thin deposit on bedrock = R1, R1A, R2, R2A, R2BE, R3AN, R4GS, R5, R5A, R5S, R6S, R7, R7T, R8, R8A, R8C, R8E, R8P, RS, R1AA or R4GA (surface deposit).

**Table 5.3** - Productive forest land regenerating (from 0 to 1.5 m) with undetermined cover

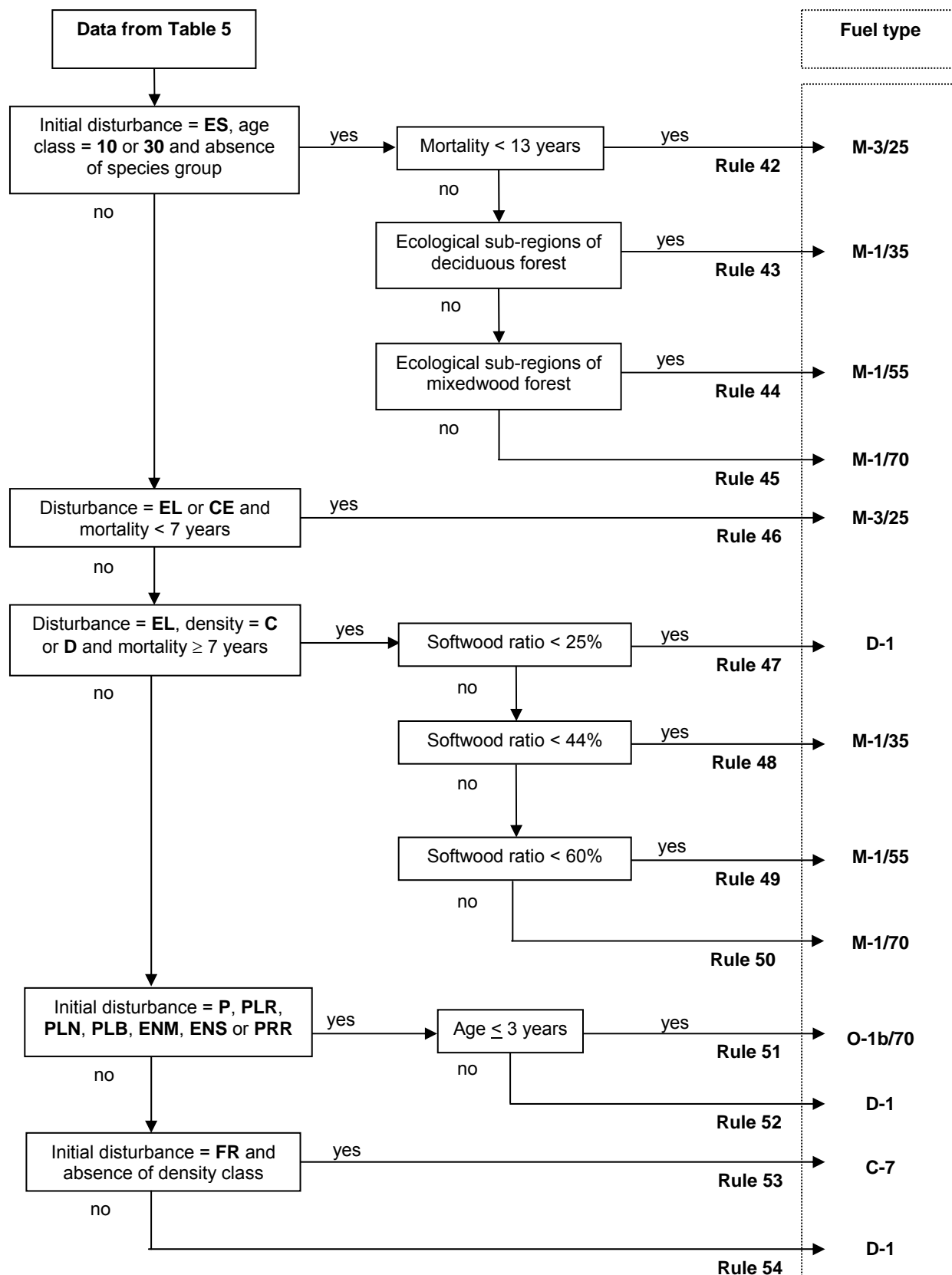




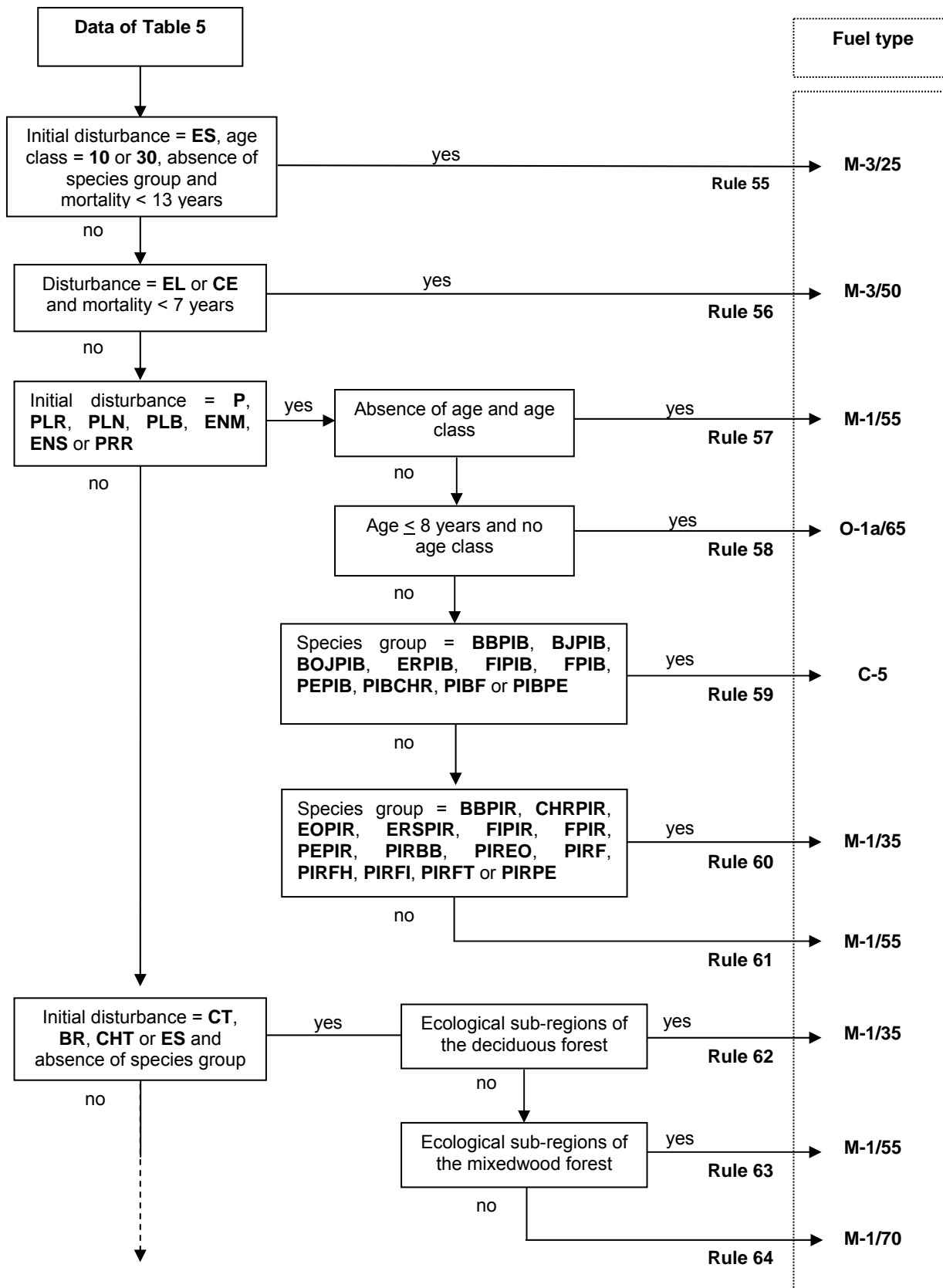
1. O-1a/65, O-1b/70, 65 and 70: These modifiers indicate the percentage of cured grass.

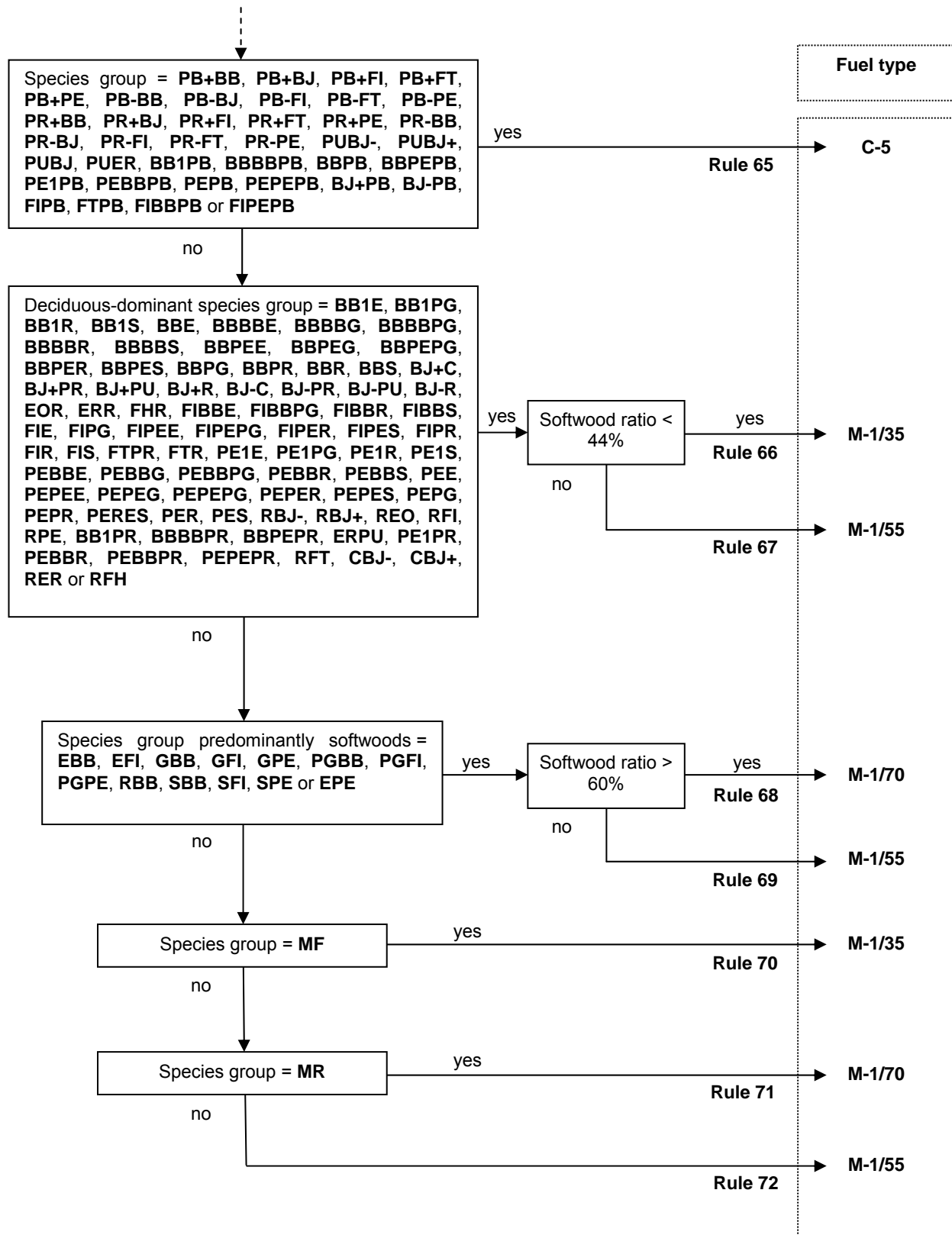


**Table 5.4** - Productive forest land with deciduous cover

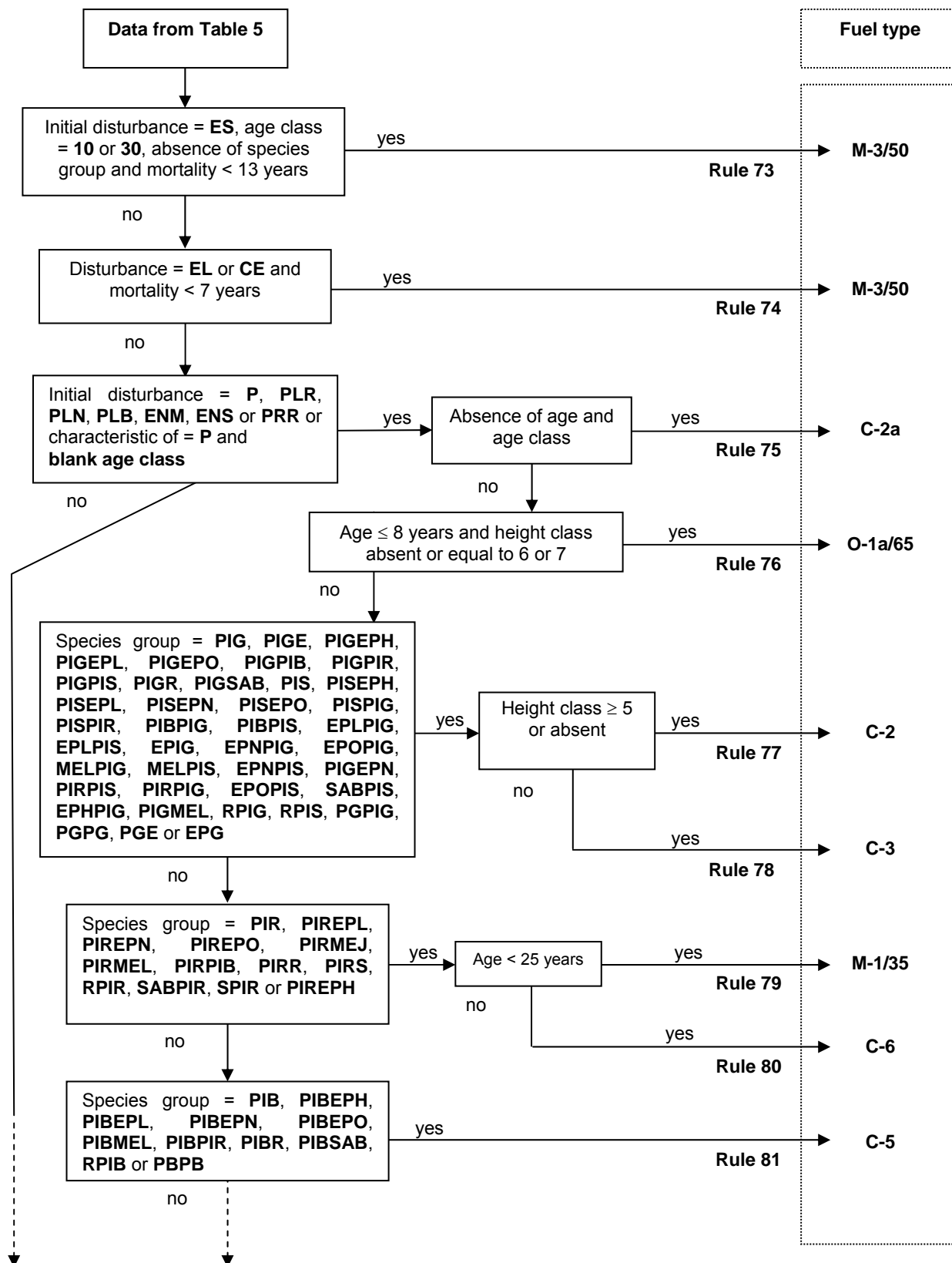


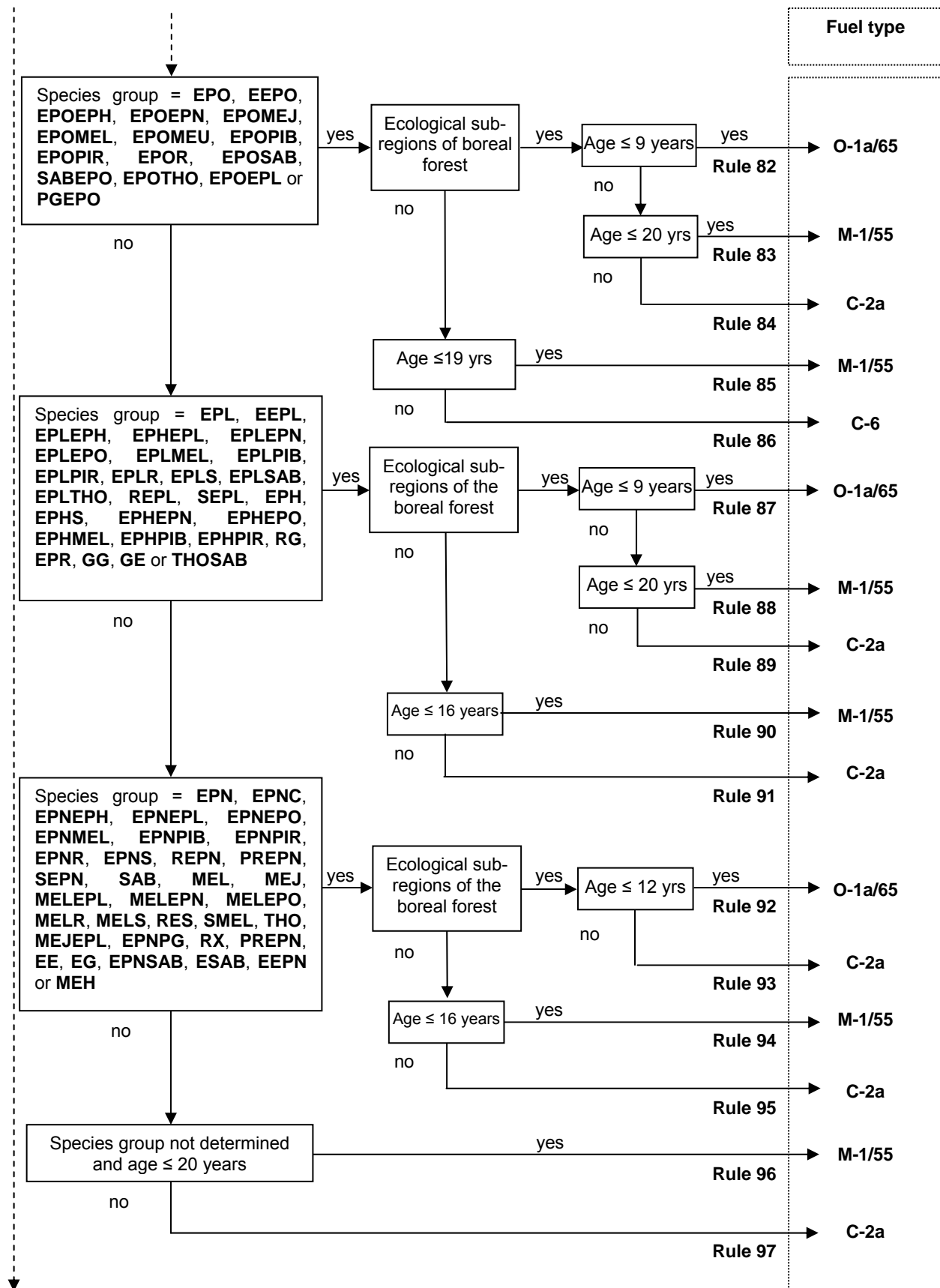
**Table 5.5** - Productive woodland with mixedwood cover

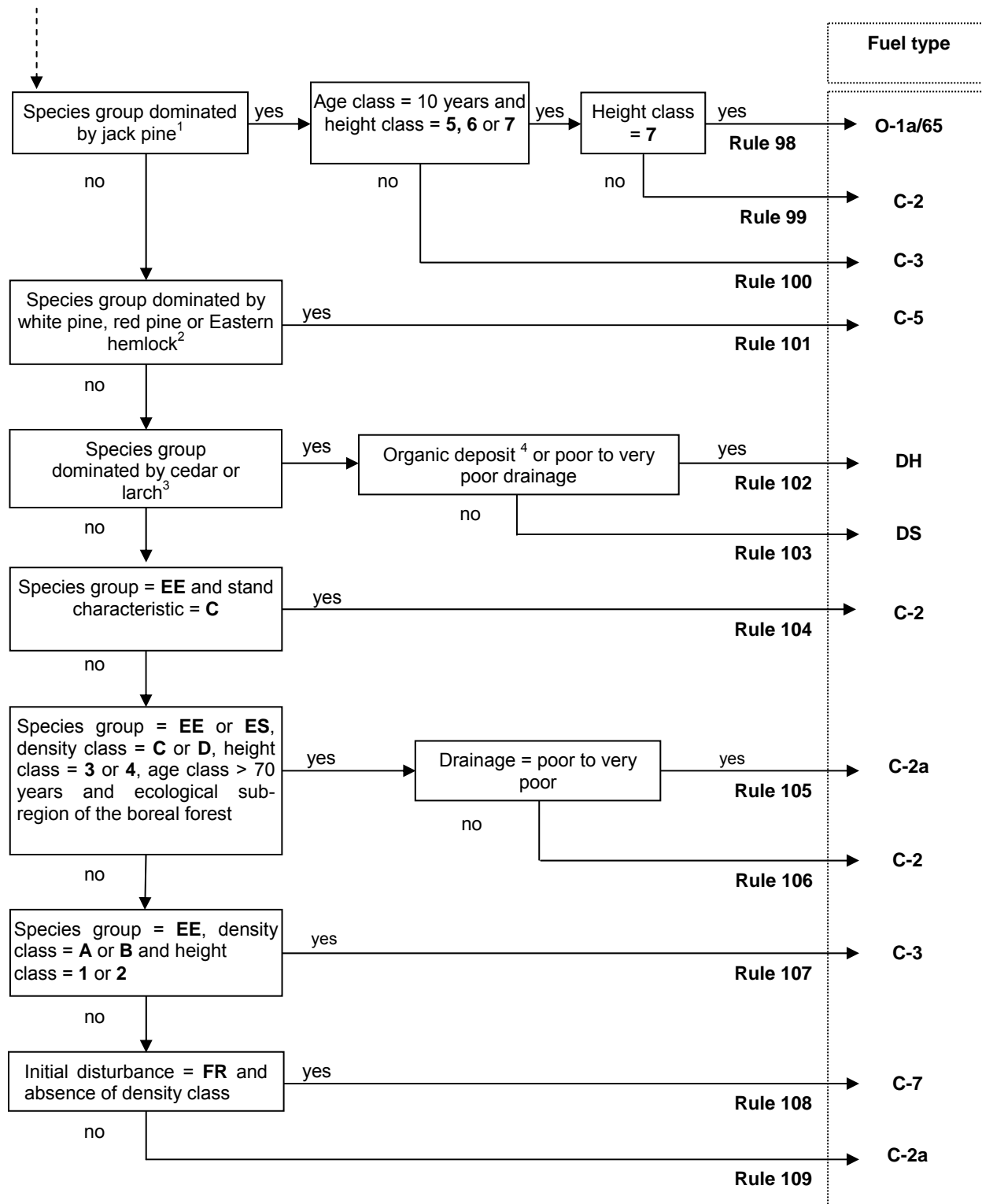




**Table 5.6** - Productive forest land with softwood cover







1. Species group dominated by jack pine: **P**GP**G**, **P**G**C**, **P**G**E**, **P**G**M**E, **P**G**P**B, **P**G**P**R, **P**G**S**, **P**G**R**, **E**P**G**, **S**P**G** or **R**P**G**.  
 2. Species group dominated by white pine, red pine or Eastern hemlock: **P**B**P**B, **P**B**C**, **P**B**E**, **P**B**M**E, **P**B**P**R, **P**B**P**G, **P**B**P**U, **P**B**S**, **P**R**P**R, **P**R**E**, **P**R**P**B, **P**R**P**G, **P**R**P**U, **P**R**S**, **P**U**P**U, **P**U**C**, **P**U**E**, **P**U**M**E, **P**U**P**R, **P**U**P**B or **P**U**S**.  
 3. Species group dominated by cedar or larch: **C**C, **C**E, **C**M**E**, **C**P**B**, **C**P**U**, **C**S, **M**E**M**E, **M**E**C**, **M**E**E**, **M**E**P**B, **M**E**P**G, **M**E**P**U, **M**E**S** or **M**E**G**.  
 4. List of organic deposits = **7**, **7**T, **7**T**M**, **7**T**Y** and **7**E (surface deposit).

## 7. Comparison of results of classification in 2001 and 2009

In the document on the classification published in 2001 (Pelletier et al., 2001), we presented a compilation of areas occupied by fuels for all territory covered by the second ten-year forest survey program. The territory of the third survey program is restricted to territory under timber supply and forest management agreements and corresponds to the intensive forest fire protection zone (Figure 3). We therefore took the results of 2001 and recalculated the total areas for each fuel type in this zone. The figures of 2001 were compared to those obtained in 2009 (Table 6). The variations between 2001 and 2009 for each fuel type are explained in Table 7.

**Table 6** - Area occupied by fuels in the intensive protection zone in 2001 and 2009

Fuel type	Area in 2001		Area in 2009		Variation (ha)
	(ha)	(%)	(ha)	(%)	
C-2 <i>other</i>	15,523,854	28.8	13,801,356	25.6	- 1,722,498
D-1	6,694,728	12.4	7,081,896	13.1	387,168
M-1/55	5,594,678	10.4	6,395,471	11.8	800,793
C-2 <i>true</i>	3,319,440	6.1	3,914,158	7.2	594,718
M-1/70	3,248,590	6.0	3,463,029	6.4	214,439
C-3	2,157,607	4.0	2,044,933	3.8	- 112,674
M-1/35	1,647,032	3.1	2,273,615	4.2	626,583
O-1 <sup>1</sup>	847,482	1.6	670,099	1.2	- 177,383
C-6	467,994	0.9	37,394	0.1	- 430,600
S-2	182,855	0.3	96,039	0.2	- 86,816
C-5	120,039	0.2	357,870	0.7	237,831
M-3 <sup>2</sup>	94,523	0.2	30,635	0.1	- 63,888
S-1	25,087	0.0	23,713	0.0	- 1,374
C-1 <sup>3</sup>	0	0.0	439,232	0.8	439,232
C-7 <sup>3</sup>	0	0.0	39,762	0.1	39,762
<b>Sub-total</b>	<b>39,923,909</b>	<b>74.0</b>	<b>40,669,202</b>	<b>75.3</b>	<b>745,293</b>
DS	1,634,570	3.0	963,329	1.8	- 671,241
BR	1,138,912	2.1	1,312,725	2.4	- 173,813
<b>Sub-total</b>	<b>2,773,482</b>	<b>5.1</b>	<b>2,276,054</b>	<b>4.2</b>	<b>- 497,428</b>
EA	4,509,479	8.3	4,620,680	8.6	111,201
AU	3,773,209	7.0	3,235,587	6.0	- 537,622
DH	3,013,557	5.6	3,192,116	5.9	178,559
<b>Sub-total</b>	<b>11,296,245</b>	<b>20.9</b>	<b>11,048,383</b>	<b>20.5</b>	<b>- 247,862</b>
<b>Total</b>	<b>53,993,636</b>	<b>100</b>	<b>53,993,639</b>	<b>100</b>	

1. Fuel types **O-1a** and **O-1b** were combined for comparison purposes since, in 2001, only type **O-1** existed.

2. Type **M-3** has three modifiers; we did not take them into account in this compilation and only kept the generic type.

3. In 2001, no forest stands were assigned as types **C-1** and **C-7**.

**Table 7** - Explanations on variations in results for 2001 and 2009

Fuel type defined in the Canadian FBP system	Explanation
<b>C-2 other</b>	Decrease of 1 722 498 ha due to cutting and inclusion in types <b>C-2 true</b> , <b>M-1/70</b> , <b>M-1/55</b> and <b>M-1/35</b> .
<b>D-1</b>	Increase of 387,168 ha mostly from type <b>AU</b> (alder stands).
<b>M-1/55</b>	Increase of 800,793 ha due to rule changes for evolving young forest stands (especially plantations).
<b>C-2 true</b>	Increase of 594,718 ha from types <b>C-2 other</b> , <b>DS</b> (lichens) and <b>C-3</b> (young jack pine), despite cutting and fire since 2001.
<b>M-1/70</b>	Increase of 214,439 ha mainly from type <b>C-2 other</b> .
<b>C-3</b>	Decrease of 112,674 ha toward type <b>C-2 true</b> ; cutting and fires also occurred.
<b>M-1/35</b>	Increase of 626,583 ha especially from <b>C-2 other</b> .
<b>O-1</b>	Decrease of 177,383 ha; this fuel type renewed itself constantly, since it represents the initial stages in the evolution of a stand after an initial disturbance. We also completely reviewed the classification of plantations and wildlands, which affected this type.
<b>C-6</b>	Decrease of 430,600 ha caused by the new classification of plantations.
<b>S-2</b>	Decrease of 86,816 ha; this fuel fluctuates according to cutting done in the five last years.
<b>C-5</b>	Increase of 237,831 ha. We reviewed the classification of mixedwood forest stands with white pine, red pine or Eastern hemlock. We associated them to the same fuel type as forest stands with softwood cover including these same species.
<b>M-3</b>	Decrease of 63,888 ha. Mortality occurred in 1999 and in 2000. Other than this new affected area, all other sectors affected by mortality in the 1970s and 1980s are regenerating; they are now associated with other types de fuels.
<b>S-1</b>	Fluctuation according to recent cutting of jack pine; decrease of 1,374 ha.
<b>C-1</b>	New fuel type associated with dry bare land with lichens.
<b>C-7</b>	New fuel type associated especially with regenerated wildlands.
Fuel type not defined in the Canadian FBP system	
<b>DS</b>	Decrease of 671,241 ha; due to the identification of lichen and type of deposit, we now find <b>C-1</b> .
<b>BR</b>	Even with an increase of 173,813 ha, fire seasons like those of 2005 and 2007 resulted in an increase in the number of raster cells with burned areas. The total area therefore fluctuates, other areas regenerate and others are planted.
Non-fuel type	
<b>EA</b>	Slight increase of 111,201 ha due to new reservoirs and mapping.
<b>AU</b>	Decrease of 537,622 ha; classification of alder stands in <b>D-1</b> .
<b>DH</b>	Increase of 178,559 ha especially caused by a change in survey standards.

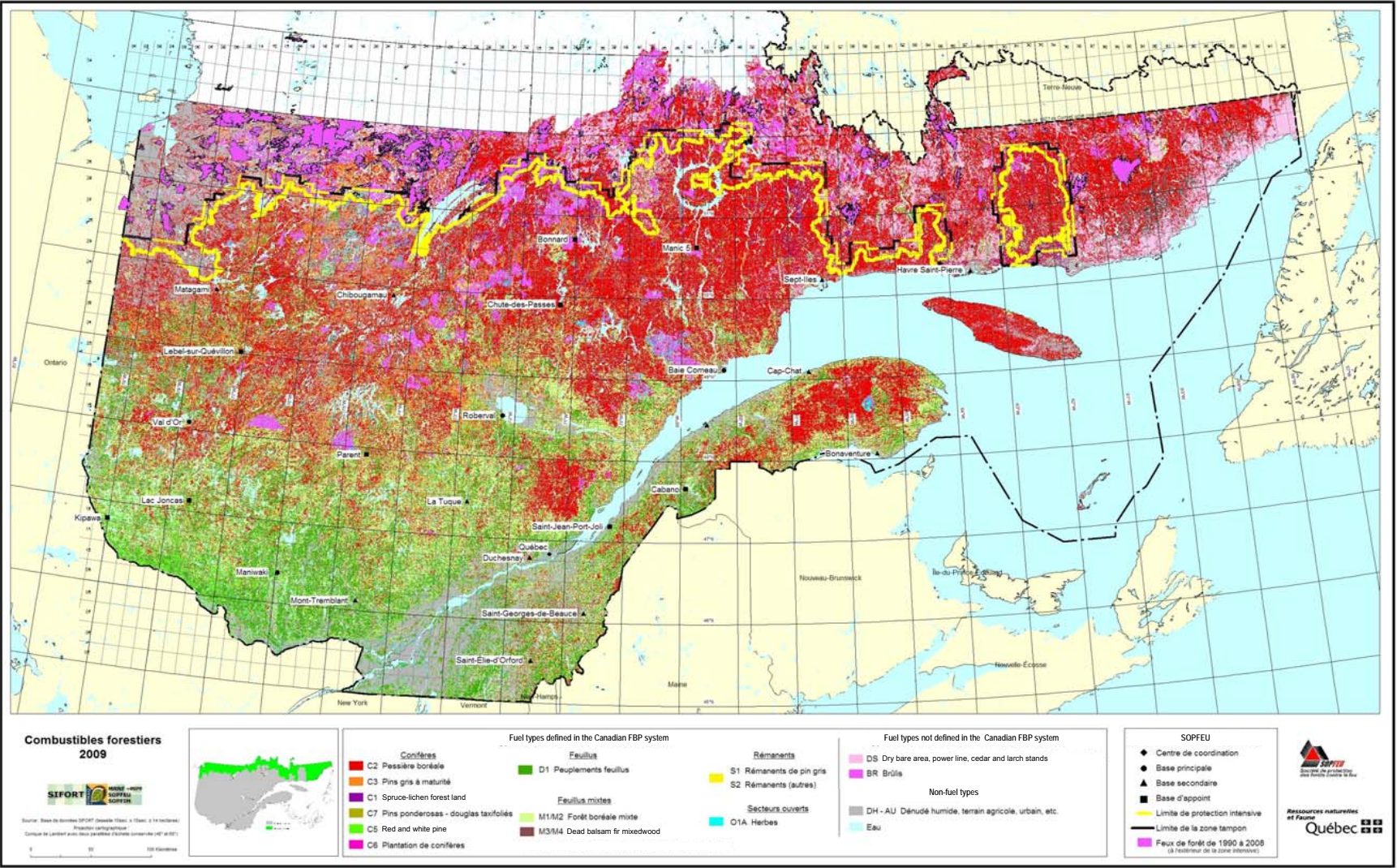


Figure 3 - Distribution of forest fuels in Québec in 2009

## **Conclusion**

In 1999, the forest fuel working group had almost finished developing the forest stand classification table using data from the second ten-year forest survey program. The third ten-year forest survey program was well advanced at that time. The use of new ecological variables appeared to be promising for establishing new classification rules. In fact, we used the moisture balance and type of deposit to help classify certain fuels more easily. In 2009, we are delivering a new classification table that makes it possible, as the one published in 2001, to track changes in a forest stand over time and to modify the fuel type associated with it year after year.

As we publish the present version of the forest stand classification, the MRNF has already undertaken its fourth forest survey program. The way it names its stands has been completely overhauled and, as a result, the number of names for species groups will go from 497 to over 14,000. It will therefore be necessary to analyze each of the new names, match them with the old names and check the distribution of stands at our sampling sites. Consequently, updating the method will not only be a complex endeavour, but will also require, in the short term, tremendous effort. The information received will help paint a portrait of the distribution of forest fuels throughout Québec so that SOPFEU can effectively fight fires.

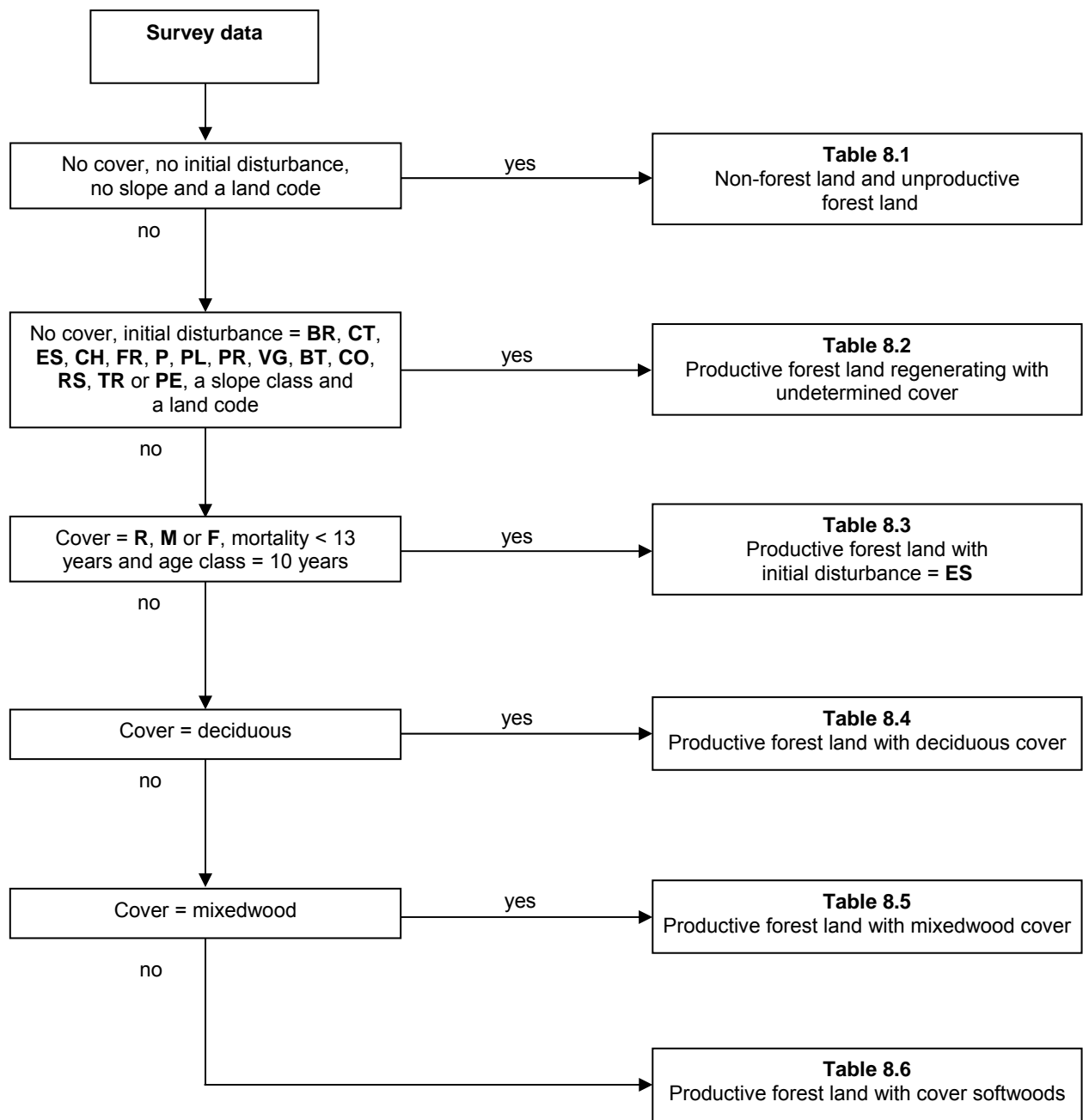
## **Appendix A Classification of forest stands as fuels – Second ten-year forest survey program**

In 2001, following the second ten-year forest survey program, the fuels working group published the document called *Classification of Forest Stands as Forest Fuels According to the Canadian Forest Fire Behavior Prediction System* (Pelletier et al., 2001). In the years that followed, the group made several changes to the classification table presented in this document. The structure was standardized and all classification rules were numbered. For this classification, 59 rules were established.

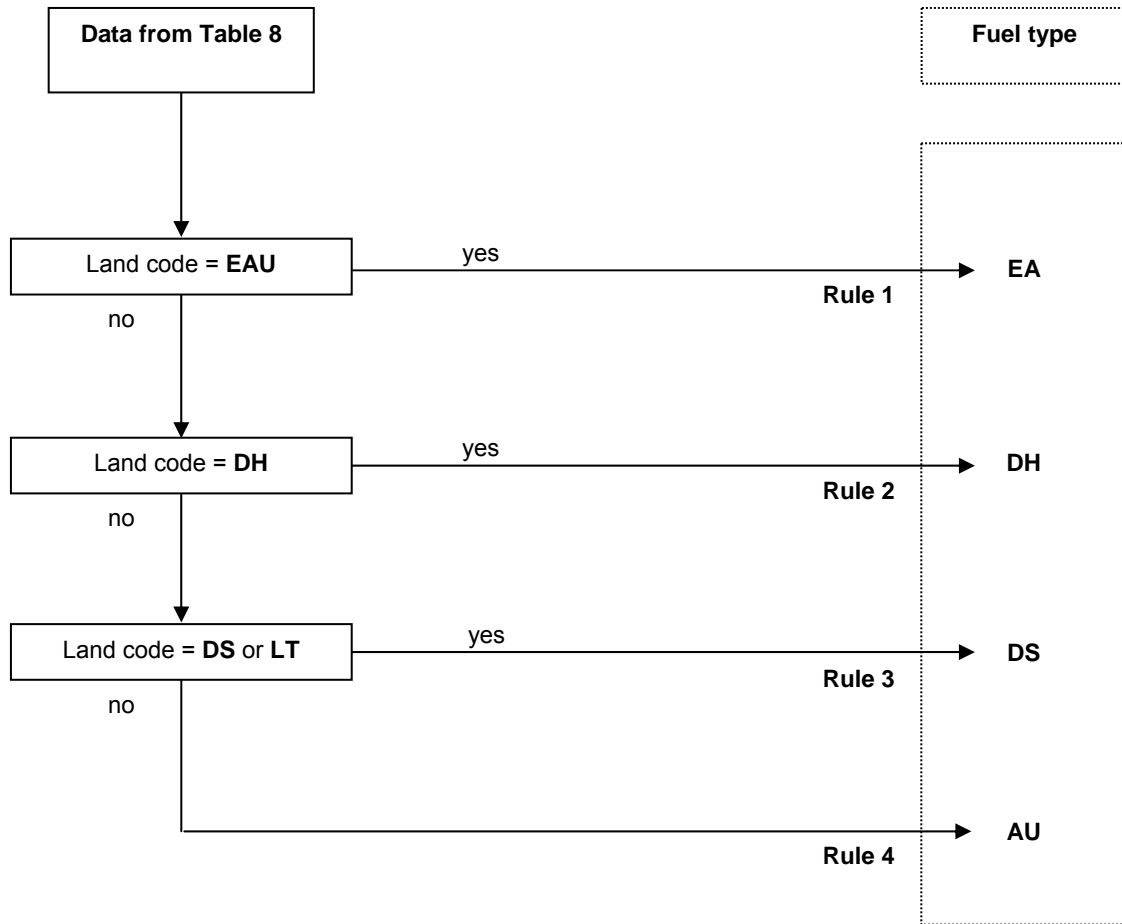
It is worth pointing out that even though we now use forest data from the third ten-year forest survey program, those of the second ten-year forest survey program are still valid. In some cases, these data may serve to specify the type of cover, the species group and the density class of a stand that existed before an initial disturbance. Furthermore, a significant part of Quebec's northern forest has not yet been surveyed, especially in the limited protection zone. The most recent data for this territory are those from the second ten-year forest survey program. They will continue to be used and appear on the forest fuels map produced every year. The updated forest stand classification table is presented in the following pages (Table 8).

The description and content of all data used in the classification table are found in the SIFORT user's guide (Pelletier, Dumont and Bédard, 2007).

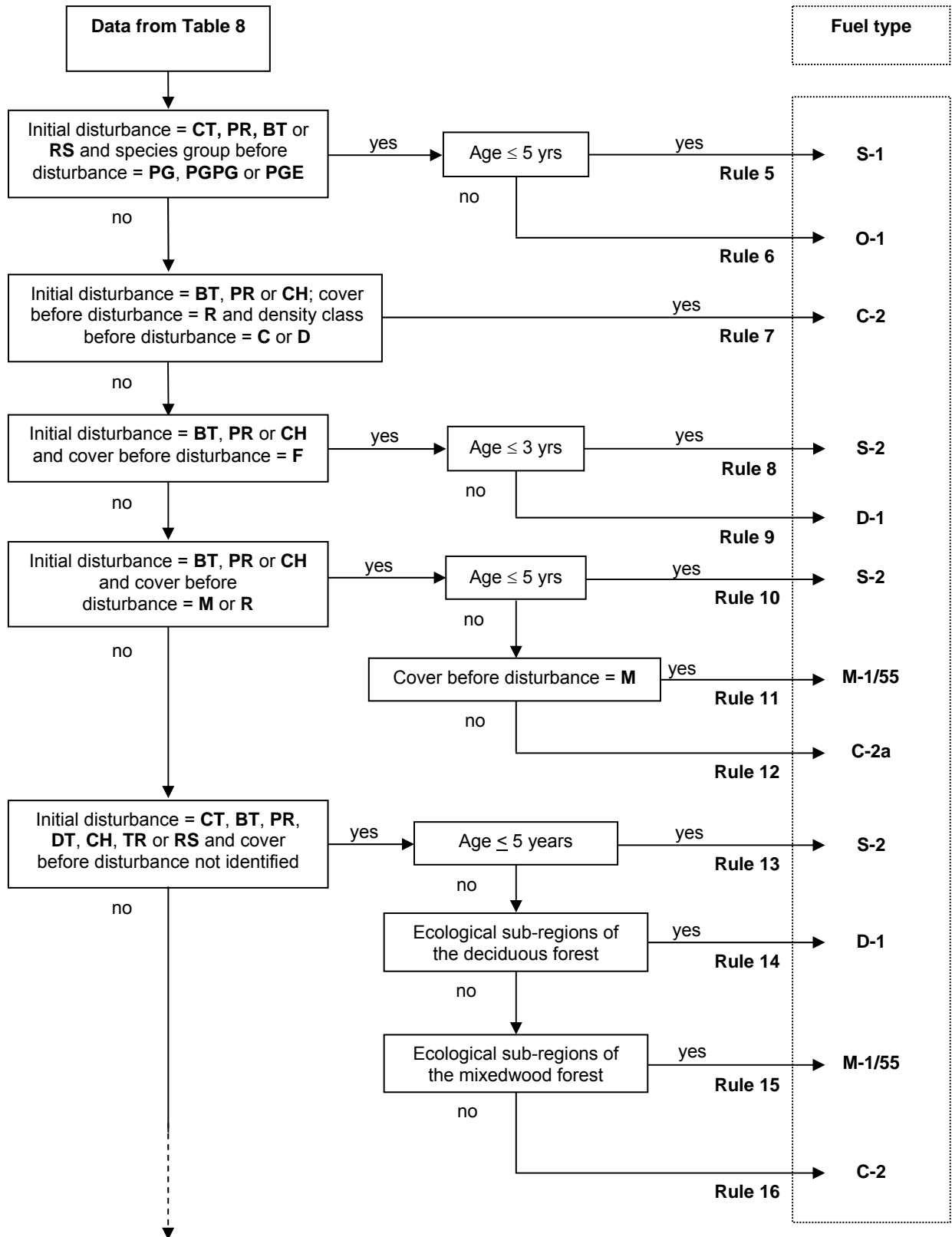
**Table 8** - Fuel classification table - Second ten-year forest survey program (February 2006)

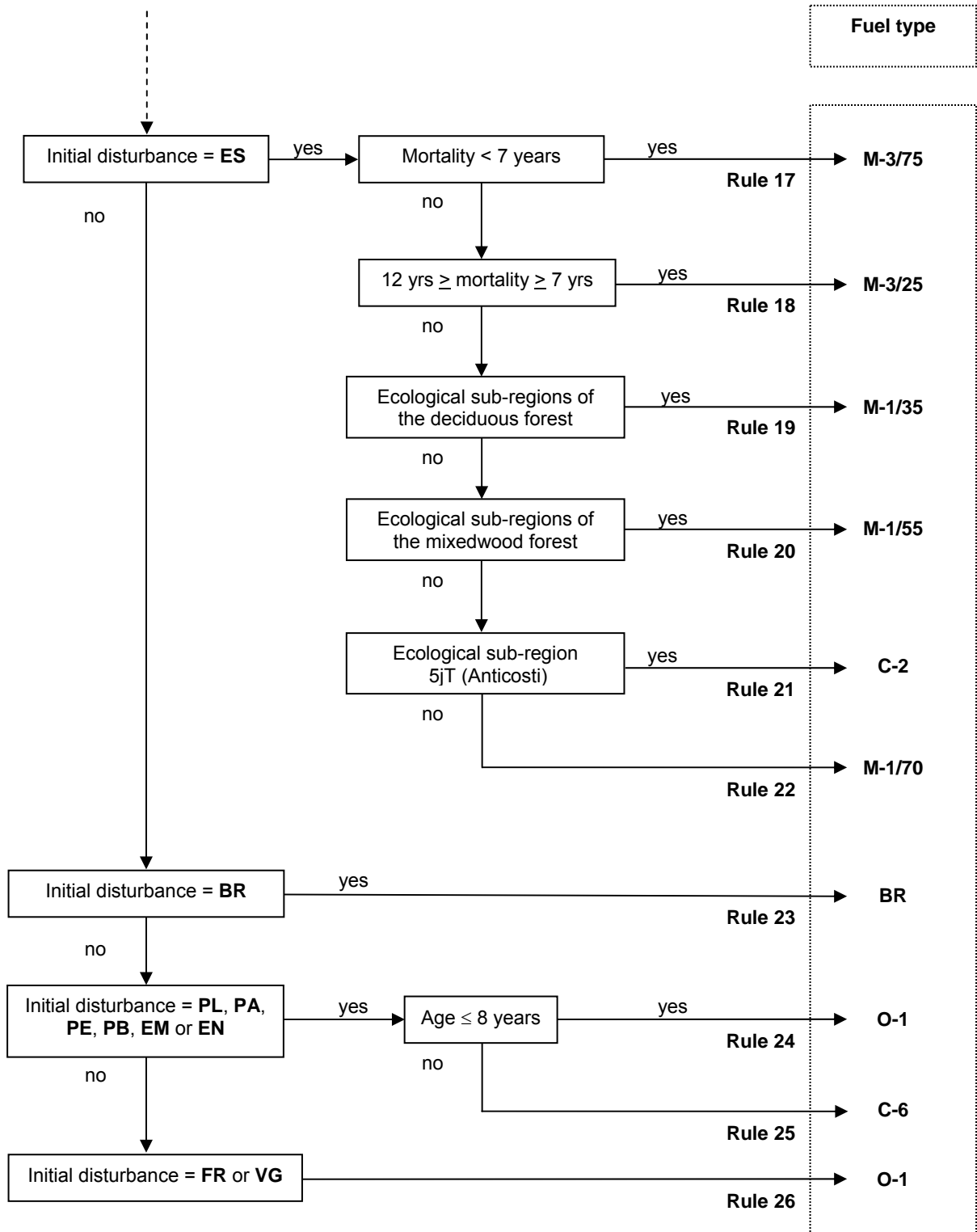


**Table 8.1** - Non-forest land and unproductive forest land

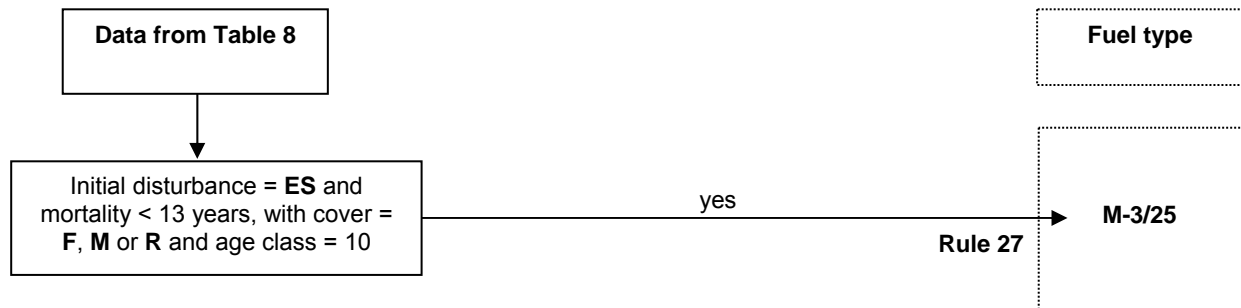


**Table 8.2** - Productive forest land regenerating with undetermined cover

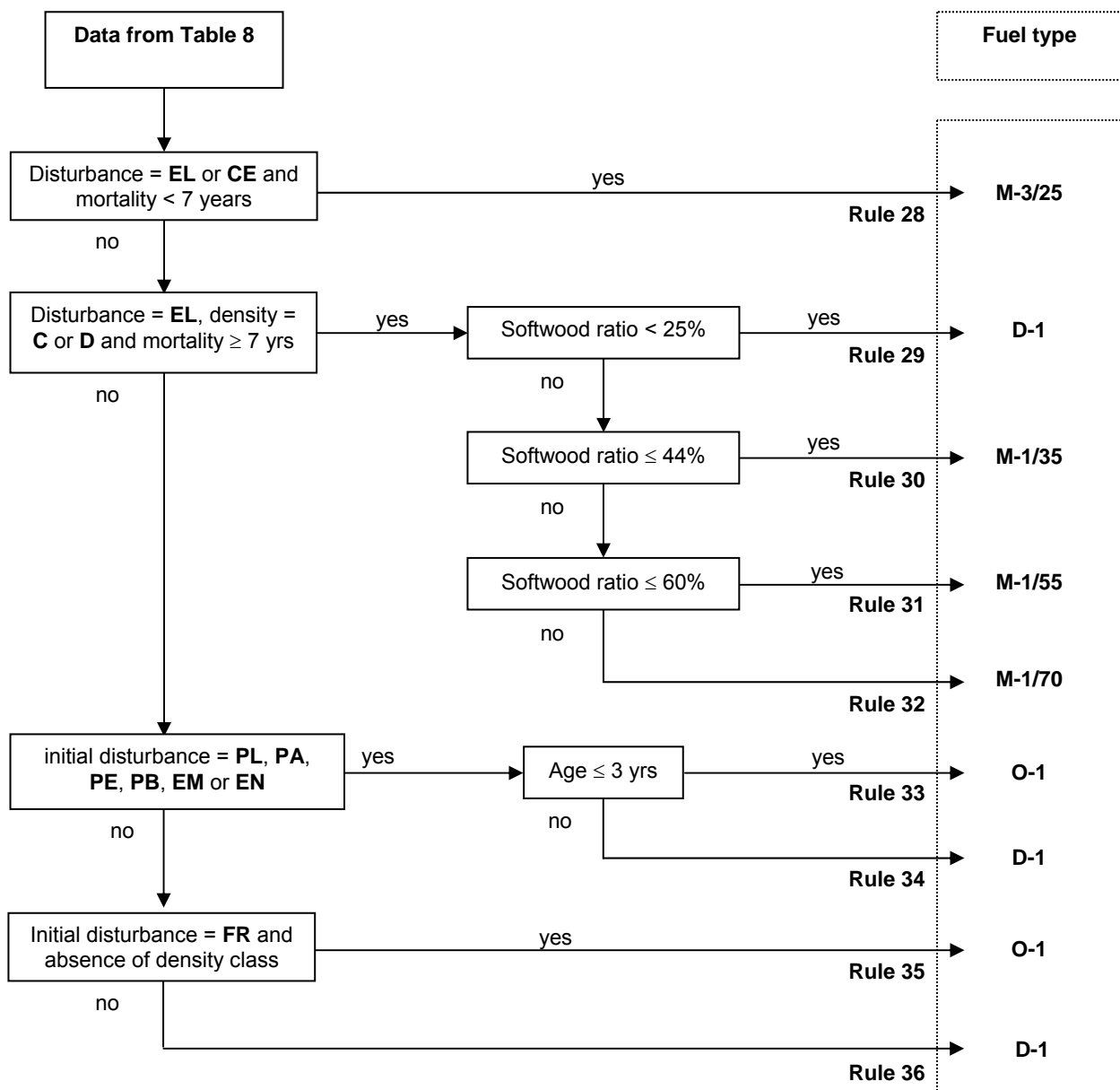




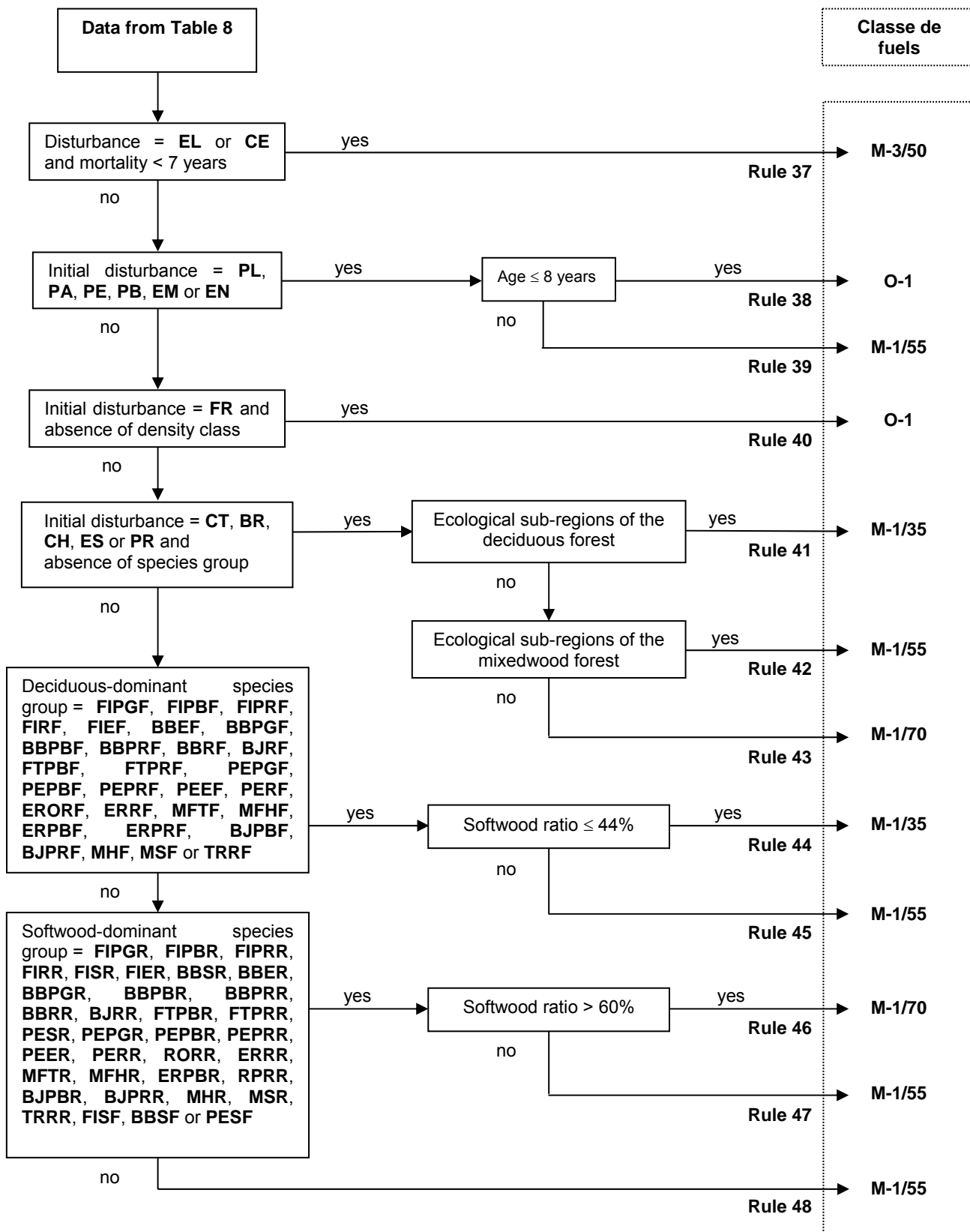
**Table 8.3 - Productive forest land with initial disturbance = ES**



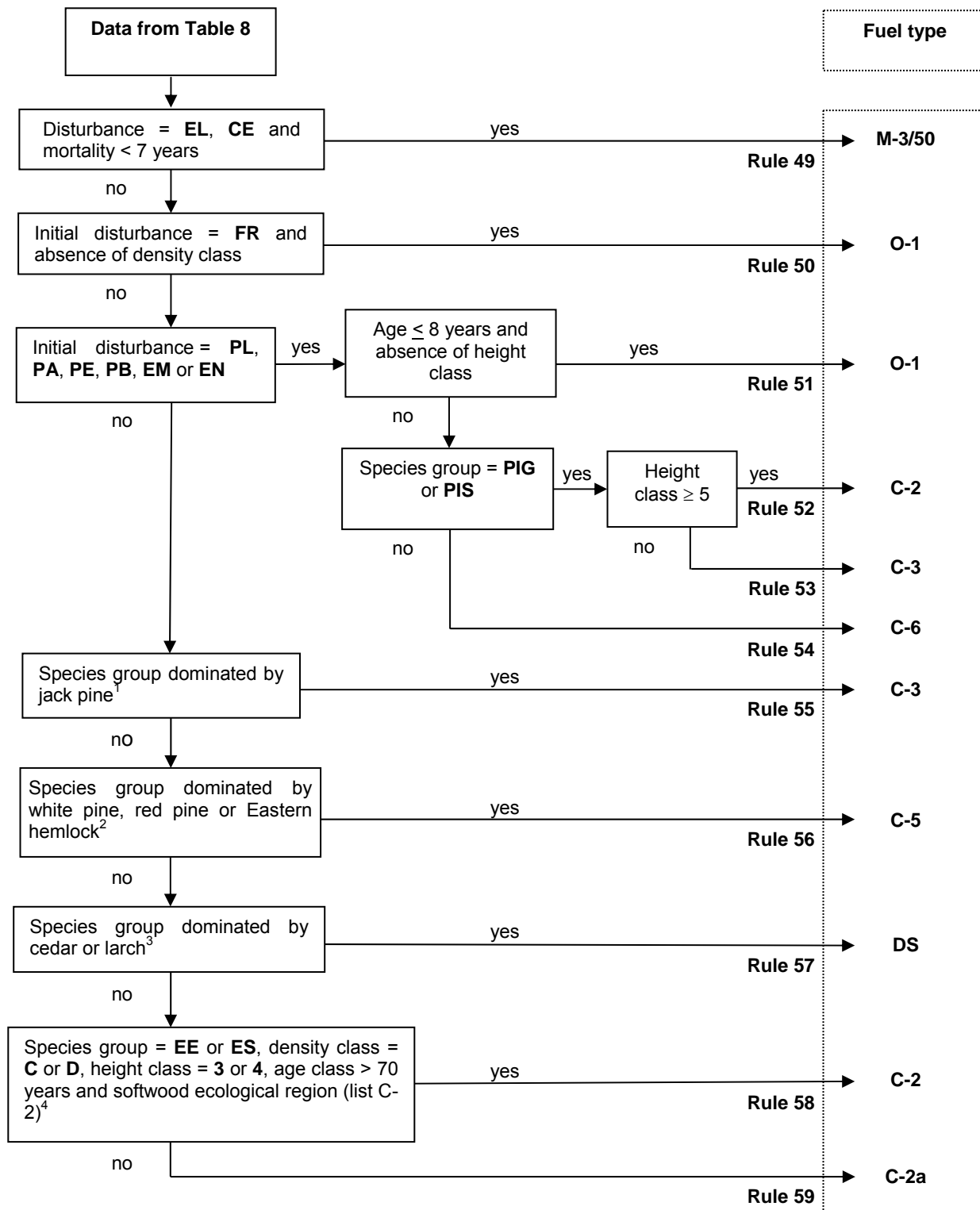
**Table 8.4 - Productive forest land with deciduous cover**



**Table 8.5** - Productive forest land with mixedwood cover



**Table 8.6** - Productive forest land with softwood cover



1. Species group dominated by jack pine: **PG, PGPG, PGC, PGE, PGME, PGPR, PGPB, PGPU, PGS, PGR, EPG, RPG** or **SPG**.  
 2. Species group dominated by white pine, red pine or Eastern hemlock: **PB, PBPB, PBC, PBE, PBME, PBPR, PBPG, PBPU, PBS, PBR, PR, PRPR, PRC, PRE, PRME, PRPB, PRPG, PRPU, PRS, PRR, PU, PUPU, PUC, PUE, PUME, PUPR, PUPG, PUPB, PUS** or **PUR**.  
 3. Species group dominated by cedar or larch\*: **C, CC, CE, CME, CPB, CPR, CPG, CPU, CS, CR, ME, MEME, MEC, MEE, MEPB, MEPR, MEPG, MEPU, MES** or **MER**.  
 4. List C-2: **EEC3120, EEC470, EEC490, EEC4120, EED370, EED390, EED3120, EED470, EED490, EED4120, ESD3120** or **ESD4120** (ecological sub-regions of the boreal forest, without disturbance).

## **Appendix B Classification of forest stands as fuels – First ten-year forest survey program**

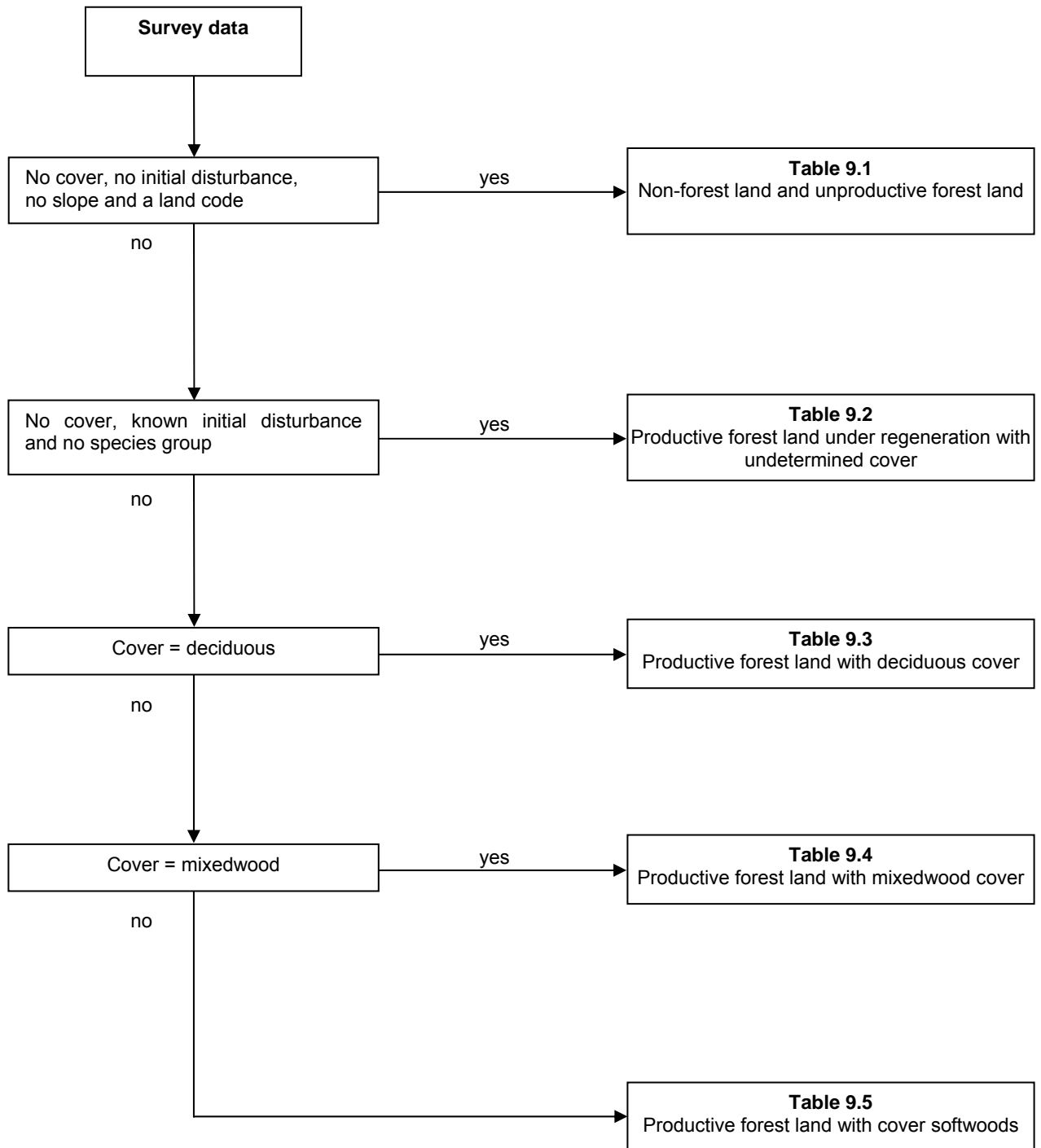
In 2001, the forest fuel working group was mandated to identify the types of fuels before fire for certain burned areas from the 1970s. Fortunately, data from the first ten-year forest survey program (1964 to 1978) had just been added to SIFORT.

We therefore established a forest stand classification table based on information gathered during reconnaissance flights of the surveyed land and the classification work undertaken since 1995. This table does not use variables such as the number of years since mortality occurred or the softwood ratio, since very few forest stands are affected by an epidemic. The list of species groups is much smaller than that of the two other inventories, which makes it easier to establish rules. During the first survey program, few of the areas affected by initial disturbances were reforested and the only known plantations were found on privately owned woodlots. We therefore established 41 classification rules to determine fuel type.

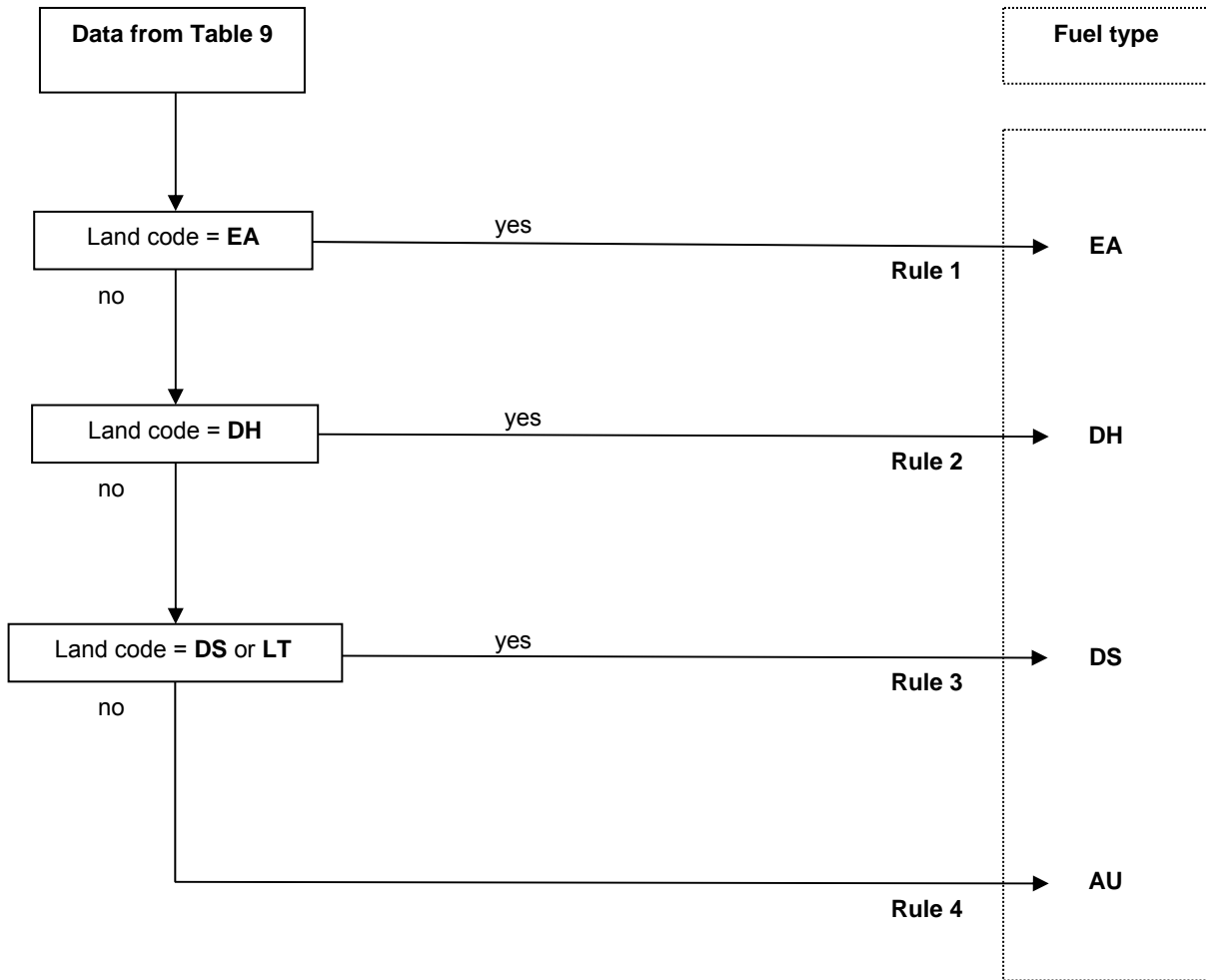
This classification table will never be validated and will not require an update. It is presented in this Appendix for the purpose of sharing our knowledge and providing access to all information that exists on the classification of forest stands as fuels.

The description and content of all data used in the classification table are found in the SIFORT user's guide (Pelletier, Dumont and Bédard, 2007).

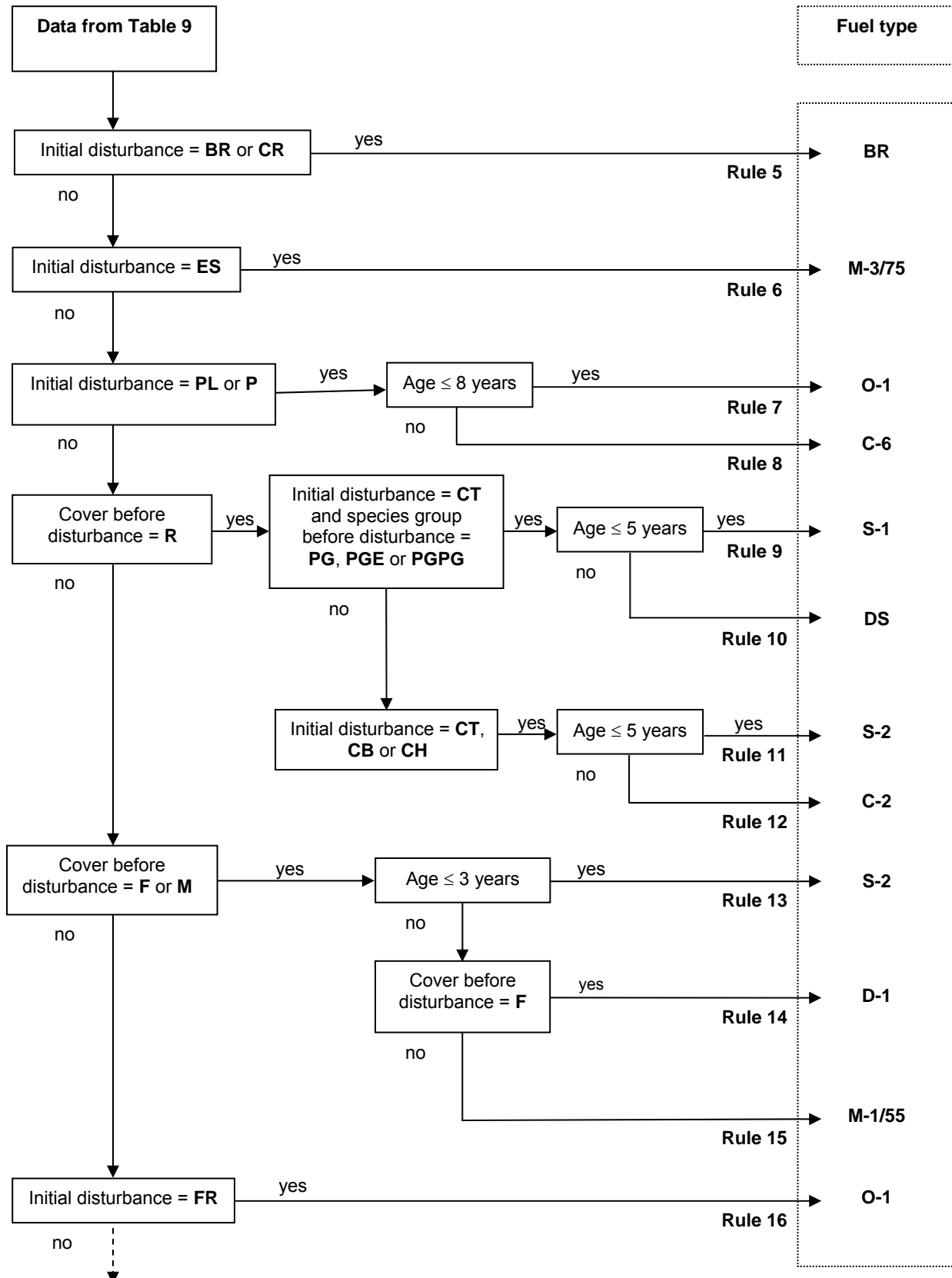
**Table 9** - Fuel classification table – First ten-year forest survey program (July 2002)



**Table 9.1** - Non-forest land and unproductive forest land



**Table 9.2** - Productive forest land regenerating with undetermined cover



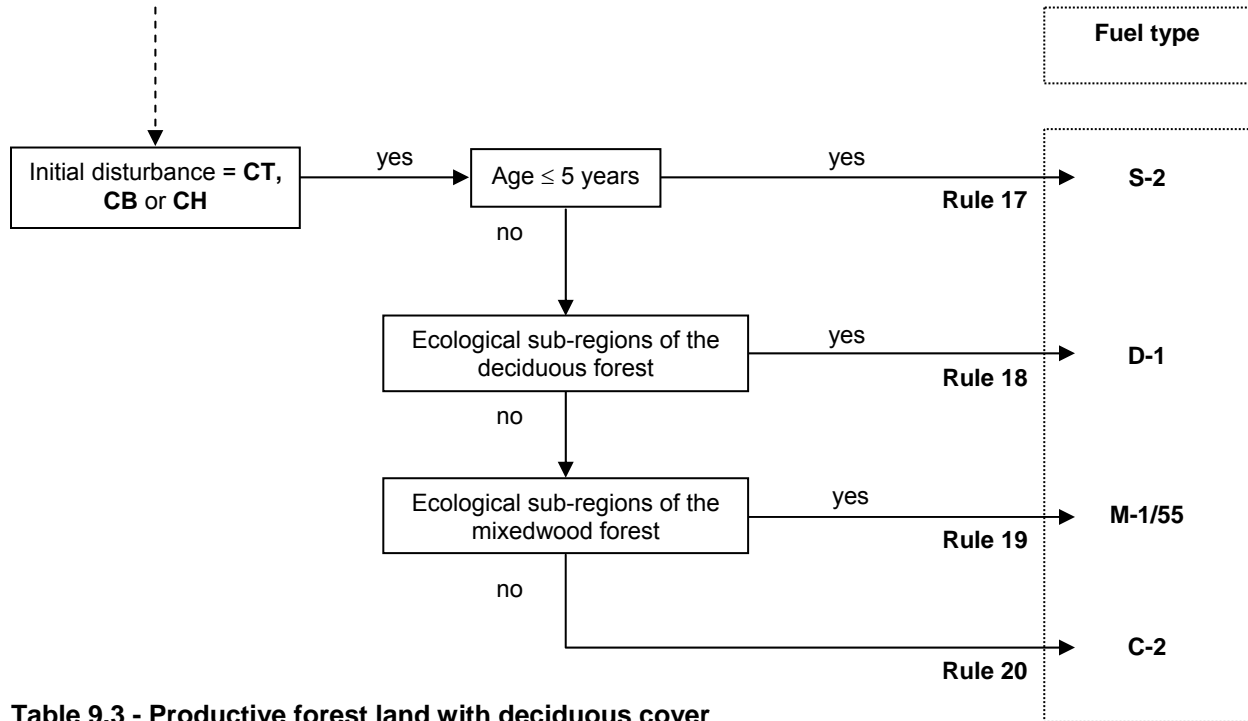
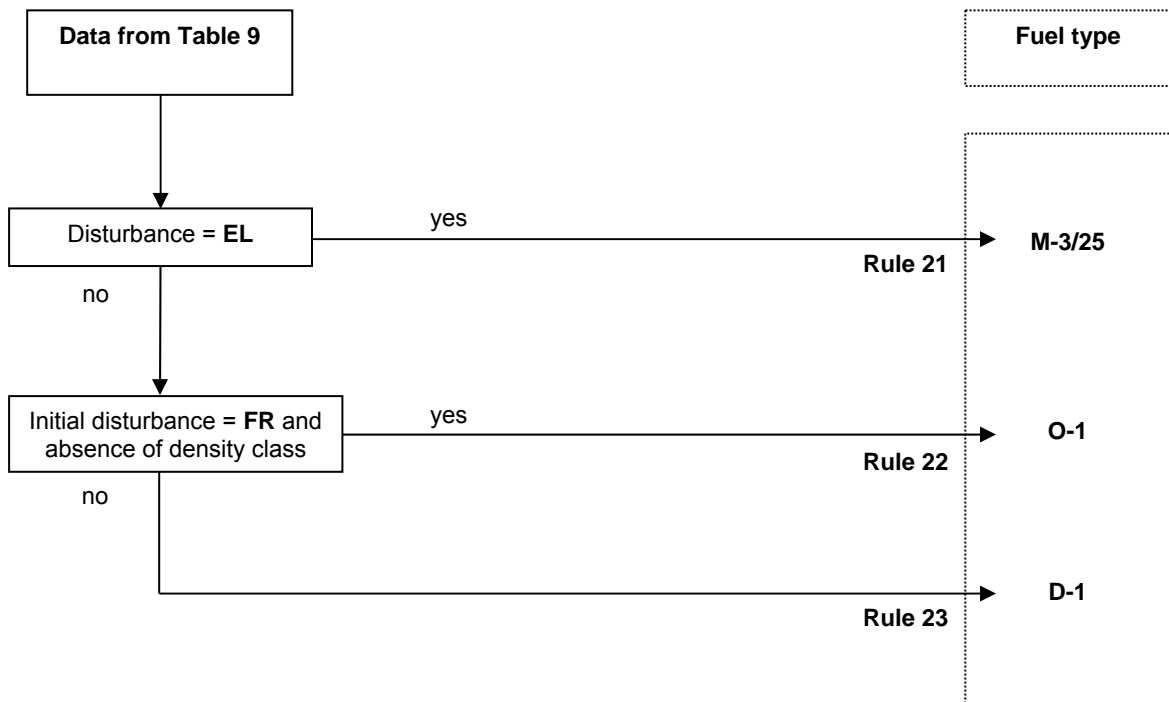
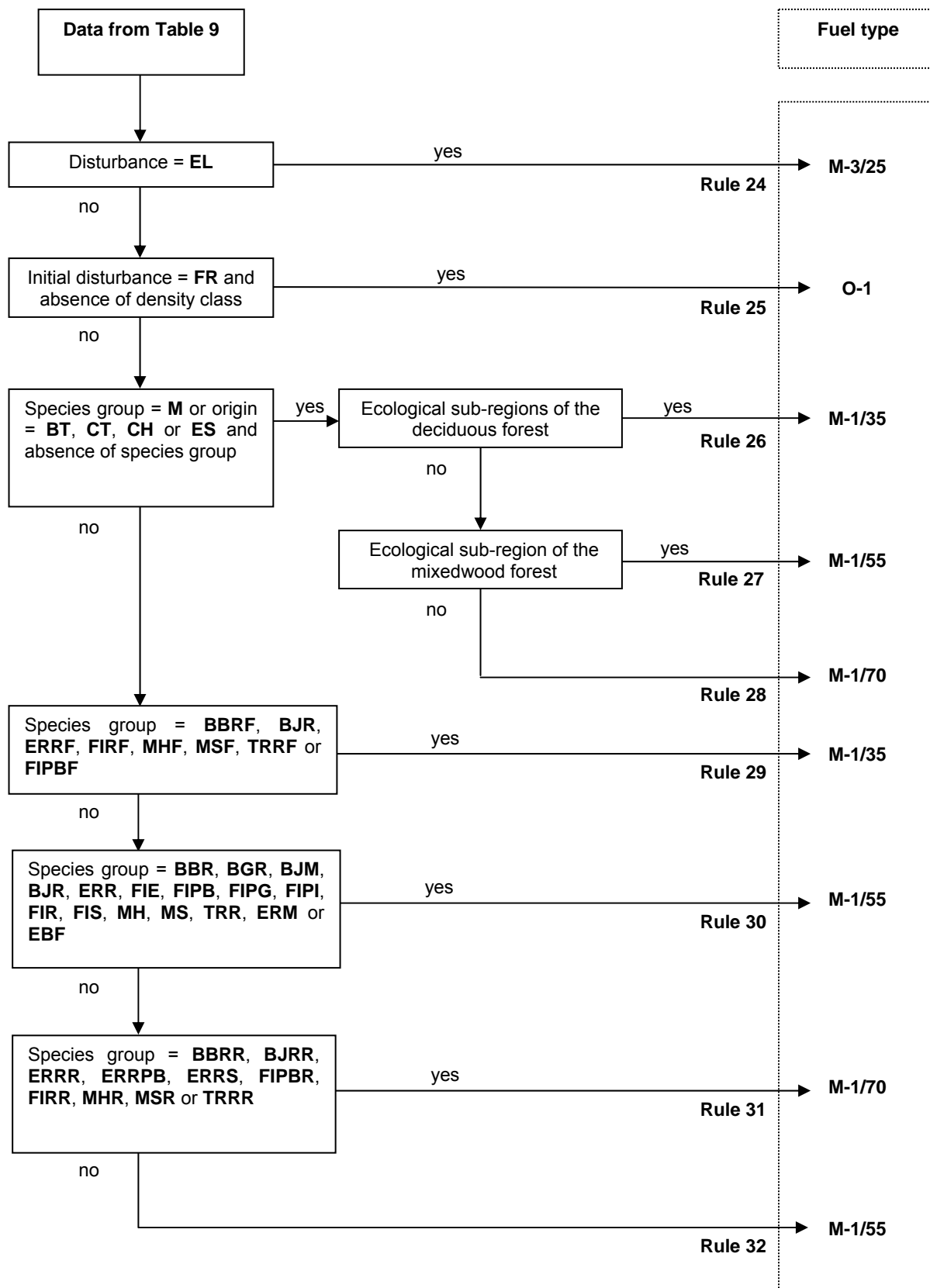


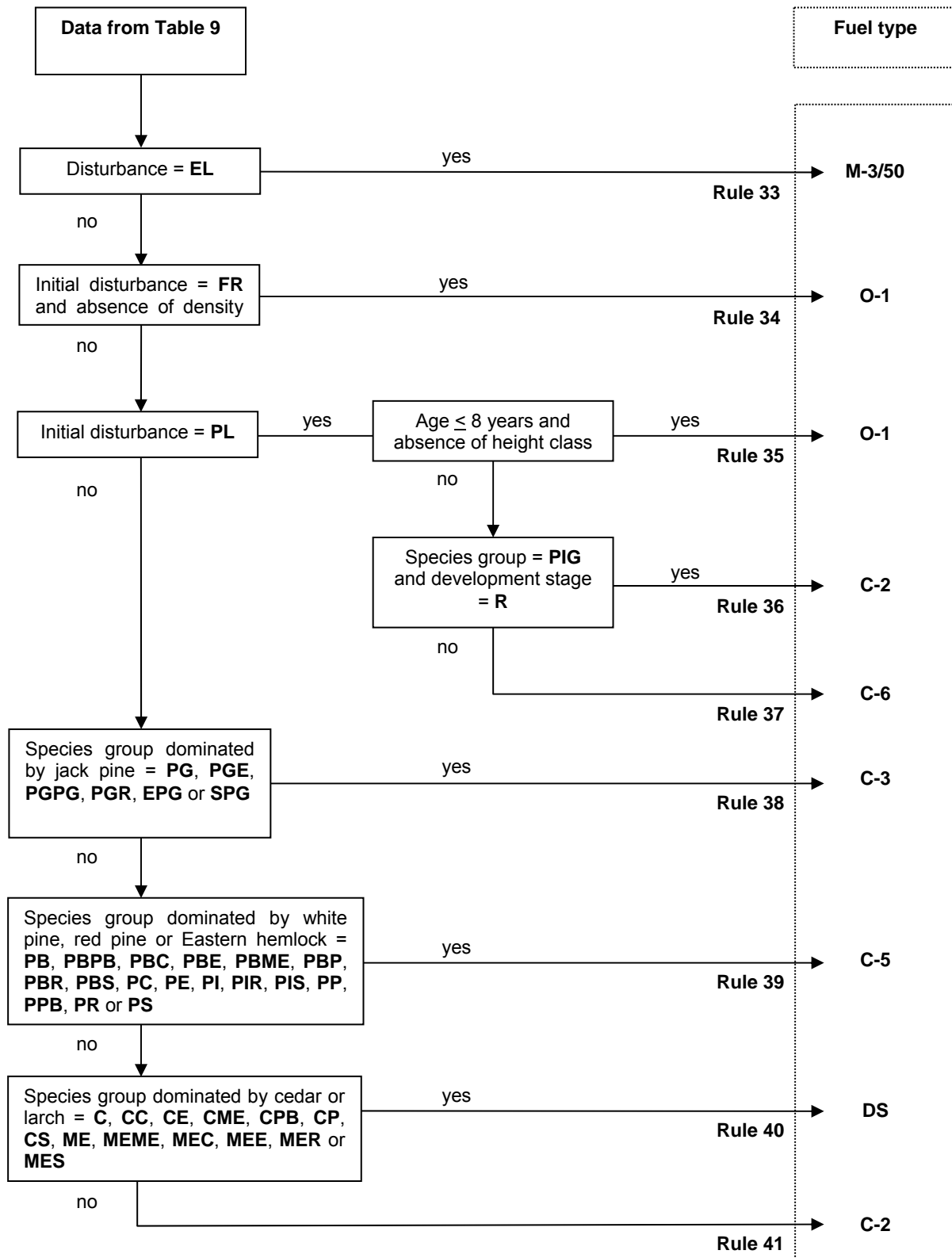
Table 9.3 - Productive forest land with deciduous cover



**Table 9.4** - Productive forest land with mixedwood cover



**Table 9.5** - Productive forest land with softwood cover



## Bibliography

- GROUPE DE TRAVAIL SUR LES DANGERS D'INCENDIE (1992). *Élaboration et structure de la méthode canadienne de prévision du comportement des incendies de forêt*, Ottawa, Forêts Canada, 68 p. [Rapport d'information ST-X-3 F].
- LETARTE, R., et al. (1995). *Norme de stratification écoforestière – Troisième programme de connaissance de la ressource forestière*, Québec, ministère des Ressources naturelles du Québec, gouvernement du Québec, 116 p.
- LÉTOURNEAU, J.-P. (2000). *Norme de cartographie écoforestière - Confection et mise à jour – Troisième programme de la connaissance de la ressource forestière*, Québec, gouvernement du Québec, ministère des Ressources naturelles, 84 p.
- LÉTOURNEAU, J.-P., et al. (2003). *Normes de cartographie écoforestière – Troisième inventaire écoforestier*, Québec, gouvernement du Québec, ministère des Ressources naturelles, de la Faune et des Parcs, 95 p.
- MINISTÈRE DE L'ÉNERGIE ET DES RESSOURCES (1984). *Normes d'inventaire forestier*, Québec, gouvernement du Québec, 177 p.
- MINISTÈRE DES RESSOURCES NATURELLES ET DE LA FAUNE (2009). *SIFORT - De l'information forestière à grande échelle*, [On-line].  
[[www.mrnf.gouv.qc.ca/forets/fimaq/information/fimaq-information.jsp](http://www.mrnf.gouv.qc.ca/forets/fimaq/information/fimaq-information.jsp)].
- PELLETIER, G., Y. DUMONT and M. BÉDARD (2007). *SIFORT - Système d'information forestière par tesselle - Manuel de l'utilisateur*, [On-line], Québec, ministère des Ressources naturelles et de la Faune, 125 p. [[www.mrnfp.gouv.qc.ca/publications/forets/fimaq/usager.pdf](http://www.mrnfp.gouv.qc.ca/publications/forets/fimaq/usager.pdf)].
- PELLETIER, G., et al. (1995). *Classification des peuplements forestiers du deuxième inventaire décennal selon la méthode canadienne de prévision du comportement des incendies de forêt*, Québec, Société de protection des forêts contre le feu, 129 p. [Internal report].
- PELLETIER, G., et al. (1999). *Modifications au classement des peuplements du deuxième inventaire décennal selon la méthode canadienne de prévision du comportement des incendies de forêt*, Québec, Société de protection des forêts contre le feu, 35 p. [Internal report].
- PELLETIER, G., et al. (2001). *Classification des peuplements forestiers en tant que combustibles, selon la méthode canadienne de prévision du comportement des incendies de forêt*, [On-line], Québec, gouvernement du Québec, ministère des Ressources naturelles, 24 p.  
[[www.mrnf.gouv.qc.ca/forets/fimaq/information/fimaq-information-resultats.jsp](http://www.mrnf.gouv.qc.ca/forets/fimaq/information/fimaq-information-resultats.jsp)].
- RESSOURCES NATURELLES CANADA (2009). *Méthode canadienne de prévision du comportement des incendies de forêt (PCI)*, [On-line], Service canadien des forêts.  
[[http://fire.nofc.cfs.nrcan.gc.ca/fr/background/bi\\_FBP\\_summary\\_f.php](http://fire.nofc.cfs.nrcan.gc.ca/fr/background/bi_FBP_summary_f.php)].
- ROBITAILLE, A., et al. (1988). *Cartographie des districts écologiques - Normes et techniques*, Québec, gouvernement du Québec, ministère de l'Énergie et des Ressources, 109 p.
- ROBITAILLE, A., and J.-P. SAUCIER (1998). *Paysages régionaux du Québec méridional*, Québec, Les Publications du Québec, 213 p.

ST-ONGE, J. (1993). *Rapport sur le classement des combustibles*, Québec, Société de conservation du Sud du Québec. [Unpublished report].

THIBAUT, M. (1985). *Les régions écologiques du Québec méridional*, [1/1,250,000 colour map], Québec, ministère de l'Énergie et des Ressources, Service de la recherche forestière et Service de la cartographie.